

CITY OF ROCKVILLE

P.O. BOX 93

229 Broadway Street East

ROCKVILLE, MN 56369

For Your Information – FYI

Council Action Needed – CA

**AGENDA
WEDNESDAY, APRIL 14, 2021
ROCKVILLE CITY HALL
5:00 P.M.**

1. Call to Order

Roll Call-JT.BB.DW.BS.BH

2. Recess to Workshop

Workshop Agenda

- a) Street Development/Construction/Design Standards
- b) Caroline Lane/Soccer Fence
- c) Stickney
- d) 5:45 p.m. Public Comment (3-minute limit - no sharing/allotting of minutes)

Reconvene Council Meeting 6:00 p.m.

3. Pledge of Allegiance

4. Roll Call – (Silence Electronic Devices)

5. Additions/Approval of Agenda

CA

6. Resolution 2021-21 Acceptance of March 2021 Donations

CA 2

7. Approval of March 2021 Bills Paid - (note any conflict-of-interest bills)

CA 3

8. Consent Agenda (approved with one motion)

CA

- a) Approval Rockville City Council Minutes of March 10 and March 31, 2021
- b) Acknowledge Review of the 1st Quarter 2021 Journal Entries
- c) Acknowledge March 2021 Building Permits
- d) Acknowledge March Sheriff's Report

22

27

44

45

9. Department Reports

- a) Sheriff's Report
- b) Public Works

FYI 45

CA 59

10. Administration

11. Action Items

- a) City of Cold Spring Invoice

CA 66

12. Other

- a) Polar Plunge
- b) Set date for Council Workshop for Public Works Building

CA

13. Council Action Worksheet, Appropriations, Allocations and Transfers

14. Closed Meeting – Per State Statute 13D.05, subd. 3.

Discuss the potential sale of City Property referred to as Brentwood Addition 2 or aka the former ARCON property.

Reconvene

- a) Summarize Closed Session
- b) Council Action

15. Adjourn

**City of Rockville, Minnesota
Resolution 2021-21**

Accepting of Donations / Contributions for March 2021

It is hereby resolved by the City of Rockville, Minnesota that:

WHEREAS; Minnesota State Statute 465.03 requires that governing bodies must formally accept donations and contributions and that every such acceptance shall be by resolution of the governing body adopted by a two-thirds majority of its members, expressing such terms in full; and

WHEREAS; The City seeks to properly accept and record donations and contributions in accordance with all state statutes and state auditor requirements;

THEREFORE; The Rockville City Council formally accepts the following donations / contributions given to the City during the month of March 2021 and agrees to their associated stipulations:

- | | | |
|----|--|------------|
| 1. | Rockville Lions Club | \$4,275.00 |
| | <i>Rockville Fire Department Equipment</i> | |

Adoption by the City Council of the City of Rockville on this 14th day of April, 2021.

Duane Willenbring, Mayor

ATTEST:

Martin M. Bode, City Administrator

CITY OF ROCKVILLE

04/07/21 12:40 PM

Page 1

***Check Detail Register©**

MARCH 2021

Check #	Check Date	Vendor Name	Amount	Invoice	Comment
10600 GCB Checkbook-MM					
1566 e	03/10/21	PERA			
	G 101-21704	PERA		\$1,762.07	RETIRE CONTR-
		Total		\$1,762.07	
1567 e	03/10/21	MN REVENUE			
	G 101-21702	State Withholding		\$504.54	STATE TAX W/H-
		Total		\$504.54	
1568 e	03/10/21	EFTPS			
	G 101-21701	Federal Withholding		\$1,533.76	FEDERAL W/H -
	G 101-21703	FICA/Medicare Withholdin		\$2,028.90	FICA/MEDICARE -
		Total		\$3,562.66	
1569 e	03/10/21	PAYMENT SERVICE NETWORK			
	E 101-46300-210	Operating Expenses		\$1.24	Monthly Credit Card fee
	E 601-49440-210	Operating Expenses		\$1.24	Monthly Credit Card fee
	E 602-49490-210	Operating Expenses		\$1.24	Monthly Credit Card fee
	E 101-41000-210	Operating Expenses		\$1.23	Monthly Credit Card fee
		Total		\$4.95	
1570 e	03/10/21	CITY OF ROCKVILLE			
	E 101-43100-210	Operating Expenses		\$65.11	WATER/SEWER MTSHP
	E 101-45122-210	Operating Expenses		\$48.62	WATER/SEWER SOFTBALL PARK
	E 101-41110-210	Operating Expenses		\$5.00	WATER/SEWER CH
	E 101-41800-210	Operating Expenses		\$20.00	WATER/SEWER CH
	E 101-46300-210	Operating Expenses		\$5.00	WATER/SEWER CH
	E 101-43100-210	Operating Expenses		\$5.00	WATER/SEWER CH
	E 101-41000-210	Operating Expenses		\$44.54	WATER/SEWER CH
		Total		\$193.27	
1571 e	03/24/21	PERA			
	G 101-21704	PERA		\$1,762.07	RETIRE CONTR-
		Total		\$1,762.07	
1572 e	03/24/21	MN REVENUE			
	G 101-21702	State Withholding		\$532.47	STATE TAX W/H-
		Total		\$532.47	
1573 e	03/24/21	EFTPS			
	G 101-21701	Federal Withholding		\$1,603.35	FEDERAL W/H -
	G 101-21703	FICA/Medicare Withholdin		\$2,097.32	FICA/MEDICARE -
		Total		\$3,700.67	
20456	02/17/21	NIEL MEIERHOFER			
	E 101-42200-310	Other Professional Servic		(\$550.00)	2016-01 FEMA SCBA grant application & narrative for air system
		Total		(\$550.00)	
20469	03/03/21	BOLTON & MENK INC			
	E 101-43100-303	Engineering Fees		\$17,425.75	264915 Public Works Building (Project Management, Meetings, Design)

CITY OF ROCKVILLE

***Check Detail Register©**

MARCH 2021

Check #	Check Date	Vendor Name	Amount	Invoice	Comment
E 602-49490-303		Engineering Fees	\$900.00	264916	Stickney Dairy (Reimb)
E 101-41000-303		Engineering Fees	\$1,350.00	264917	Harstad Travel Plaza Development (Reimb)
E 101-41000-303		Engineering Fees	\$355.00	264917	Loves Travel Plaza Site Improvements (Reimb)
		Total	\$20,030.75		
20470	03/03/21	DELTA ELECTRIC			
E 602-49490-296		Lk Sewer Contr Srv	\$1,818.25	22821	Grinderstation calls Lake Area
E 602-49490-289		Grinderstation Repairs/Par	\$215.00	22821	Relay
E 101-42500-220		Repair/Operating Expense	\$95.00	22821	Took apart old siren @ school not repairable
		Total	\$2,128.25		
20471	03/03/21	GOPHER STATE ONE-CALL			
E 602-49490-291		Locates	\$3.38		LOCATE TICKETS-SWR DEPT
E 601-49440-291		Locates	\$3.37		LOCATE TICKETS-WTR DEPT
		Total	\$6.75		
20472	03/03/21	HAWKINS, INC			
E 601-49440-217		PL LK Chemicals/Chem P	\$10.00	4882967	Chlorine Cylinder
E 601-49440-216		Chemicals/Chem Products	\$10.00	4882968	Chlorine Cylinder
		Total	\$20.00		
20473	03/03/21	INSPECTRON INC.			
E 101-46300-305		Building Inspection Fees	\$689.41	2021-025	Building Inspection & review
		Total	\$689.41		
20474	03/03/21	KIESS BROS			
E 101-43100-212		Gas & Oil	\$283.28		Fuel Streets
E 101-45122-212		Gas & Oil	\$22.01		Fuel Parks
E 601-49440-212		Gas & Oil	\$20.12		Fuel Water
E 602-49490-212		Gas & Oil	\$20.12		Fuel Sewer
		Total	\$345.53		
20475	03/03/21	LYNN PLUMSKI			
E 101-41000-106		Cleaning Person	\$9.38		CITY HALL
E 101-41110-106		Cleaning Person	\$9.38		CITY HALL
E 101-41800-106		Cleaning Person	\$9.38		CITY HALL
E 101-42200-106		Cleaning Person	\$78.12		CITY HALL/FIRE HALL
E 101-43100-106		Cleaning Person	\$9.38		CITY HALL
E 101-46300-106		Cleaning Person	\$9.37		CITY HALL
E 601-49440-106		Cleaning Person	\$9.37		CITY HALL
E 602-49490-106		Cleaning Person	\$9.37		CITY HALL
		Total	\$143.75		
20476	03/03/21	MIDWAY IRON & METAL CO INC			
E 101-43100-220		Repair/Operating Expense	\$53.00	485381	Unit 5 repair of the wing/arm on plow truck
		Total	\$53.00		
20477	03/03/21	MN DEPT OF HEALTH			
G 601-20510		MDH Fee-Due to Other G	\$699.00		QTRLY MDH FEE TO STATE
		Total	\$699.00		

CITY OF ROCKVILLE

***Check Detail Register©**

MARCH 2021

Check #	Check Date	Vendor Name	Amount	Invoice	Comment
20478	03/03/21	RIVER POWER & EQUIPMENT INC			
G 101-20200		Accounts Payable	\$327.00	28798	45122-220 Repair Rear glass TYM tractor
		Total	\$327.00		
20479	03/03/21	TOM KRAEMER, INC			
E 101-43100-384		Refuse/Garbage Disposal	\$46.25		Old shop bulbs
		Total	\$46.25		
20480	03/03/21	USABLE LIFE			
G 101-21709		Short/Long-Term Disability	\$64.96	3655697	EMPLOYEE PORTION
E 101-41000-134		Employer Paid Life Insura	\$29.60	3655697	LTD/STD
E 101-41000-135		Empl r Pd Short/Long Ter	\$259.95	3655697	LTD/STD
		Total	\$354.51		
20481	03/03/21	XCEL ENERGY			
E 101-45122-381		Electric Utilities	\$42.28		1001 OTHMAR LN
E 101-43100-387		Street Lighting-Electricity	\$713.52		STREETLGHTS
E 601-49440-381		Electric Utilities	\$110.33		209 BRDWY & 562 CHESTNUT
E 602-49490-381		Electric Utilities	\$110.33		209 BRDWY & 562 CHESTNUT
E 101-43100-381		Electric Utilities	\$110.33		209 BRDWY & 562 CHESTNUT
E 602-49490-381		Electric Utilities	\$322.26		398 BROADWAY ST
E 601-49440-381		Electric Utilities	\$208.40		423 MAPLE ST & 560 CHESTNUT
E 101-45122-381		Electric Utilities	\$60.74		1000 BRDWY BALLPK BALL PRG
E 101-41000-381		Electric Utilities	\$51.21		229 BROADWAY
E 101-41800-381		Electric Utilities	\$51.22		229 BROADWAY
E 101-43100-381		Electric Utilities	\$51.22		229 BROADWAY
E 101-46300-381		Electric Utilities	\$51.22		229 BROADWAY
E 601-49440-381		Electric Utilities	\$51.22		229 BROADWAY
E 602-49490-381		Electric Utilities	\$51.22		229 BROADWAY
E 101-41110-381		Electric Utilities	\$51.22		229 BROADWAY
E 101-42200-381		Electric Utilities	\$459.99		24001 FIRE HALL DR
		Total	\$2,496.71		
20482	03/12/21	ADVANCE AUTO PARTS			
E 101-42200-220		Repair/Operating Expense	\$320.35		Unit 1 wire connectors, clips, conductors, elect taple, Trailer connn, heat shrink
E 101-43100-220		Repair/Operating Expense	\$108.79		Water pump unit 3
E 101-43100-220		Repair/Operating Expense	\$15.57		Unit 3 Lock Clyinder
E 101-43100-220		Repair/Operating Expense	\$32.28		Unit 3 Antifrz
		Total	\$476.99		
20483	03/12/21	ARAMARK			
E 101-41000-209		Cleaning Supplies	\$28.08		RENTAL OF RUGS/MOPS-CITY HALL
E 101-41110-209		Cleaning Supplies	\$9.00		RENTAL OF RUGS/MOPS-CITY HALL
E 101-42200-209		Cleaning Supplies	\$9.00		RENTAL OF RUGS/MOPS-CITY HALL
E 101-43100-209		Cleaning Supplies	\$9.00		RENTAL OF RUGS/MOPS-CITY HALL
E 101-46300-209		Cleaning Supplies	\$9.00		RENTAL OF RUGS/MOPS-CITY HALL
E 601-49440-209		Cleaning Supplies	\$9.00		RENTAL OF RUGS/MOPS-CITY HALL
E 602-49490-209		Cleaning Supplies	\$9.00		RENTAL OF RUGS/MOPS-CITY HALL
		Total	\$82.08		

CITY OF ROCKVILLE

04/07/21 12:40 PM

Page 4

***Check Detail Register©**

MARCH 2021

Check #	Check Date	Vendor Name	Amount	Invoice	Comment
20484	03/12/21	AT & T MOBILITY			
E 101-42200-321		Telephone		\$76.46	FirstNet Fire Dept wireless
		Total		\$76.46	
20485	03/12/21	BLUE CROSS BLUE SHIELD OF MN			
G 101-21705		Health Insurance		\$289.66	EMPLOYEE PORTION HEALTH INS.
G 101-21706		City Portion Health Ins		\$1,158.63	EMPLOYER PD HEALTH INS.
		Total		\$1,448.29	
20486	03/12/21	CENTRAL MCGOWAN, INC			
E 101-42200-219		Fire Rescue Supplies		\$25.58	MEDICAL OXYGEN/RENT-FIRE DEPT
		Total		\$25.58	
20487	03/12/21	COLD SPRING RECORD INC			
E 602-49490-340		Advertising/Printing/Publis	\$29.51	44322	envelopes, Fees and Charge
E 601-49440-340		Advertising/Printing/Publis	\$29.51	44322	envelopes, Fees and Charge
E 101-43100-340		Advertising/Printing/Publis	\$159.92	44322	Advertise for Bids (PW building), envelopes
E 101-46300-340		Advertising/Printing/Publis	\$118.76	44322	Eichi Public Hearing, envelopes, Fees and charges
E 101-41000-340		Advertising/Printing/Publis	\$29.51	44322	envelopes, Fees and Charges
E 101-42200-340		Advertising/Printing/Publis	\$19.67	44322	envelopes
		Total		\$386.88	
20488	03/12/21	GOVERNMENT BRANDS SHARED SERIV			
E 101-41110-323		Internet/E-mail/Web Site	\$50.00	208305	Jerry T email
		Total		\$50.00	
20489	03/12/21	GUARDIAN FLEET SAFETY			
E 101-42200-220		Repair/Operating Expense	\$389.50	21-0085	Lightbar for Suburban
		Total		\$389.50	
20490	03/12/21	INTEGRATED PROCESS SOLUTIONS			
E 602-49490-221		PL LK/Lake Repair/operati	\$407.50	001164	Grand Lake Lift station (Intrinsic Relay Install)
		Total		\$407.50	
20491	03/12/21	LYNN PLUMSKI			
E 101-41000-106		Cleaning Person	\$9.38		CITY HALL
E 101-41110-106		Cleaning Person	\$9.38		CITY HALL
E 101-41800-106		Cleaning Person	\$9.38		CITY HALL
E 101-42200-106		Cleaning Person	\$78.12		CITY HALL/FIRE HALL
E 101-43100-106		Cleaning Person	\$9.38		CITY HALL
E 101-46300-106		Cleaning Person	\$9.37		CITY HALL
E 601-49440-106		Cleaning Person	\$9.37		CITY HALL
E 602-49490-106		Cleaning Person	\$9.37		CITY HALL
		Total		\$143.75	
20492	03/12/21	MIDCO			
E 101-42200-323		Internet/E-mail/Web Site	\$75.00		FIRE HALL
E 101-46300-323		Internet/E-mail/Web Site	\$9.44		CITY HALL
E 101-43100-323		Internet/E-mail/Web Site	\$9.44		CITY HALL
E 602-49490-323		Internet/E-mail/Web Site	\$9.44		CITY HALL
E 601-49440-323		Internet/E-mail/Web Site	\$9.44		CITY HALL

CITY OF ROCKVILLE

***Check Detail Register©**

MARCH 2021

Check #	Check Date	Vendor Name	Amount	Invoice	Comment
E 101-41000-323		Internet/E-mail/Web Site	\$9.48		CITY HALL
E 101-41110-323		Internet/E-mail/Web Site	\$9.44		CITY HALL
E 101-41800-323		Internet/E-mail/Web Site	\$9.44		CITY HALL
E 101-45122-323		Internet/E-mail/Web Site	\$9.44		CITY HALL
E 101-42500-323		Internet/E-mail/Web Site	\$9.44		CITY HALL
		Total	\$160.00		
20493	03/12/21	STEARNS ELECTRIC ASOC INC			
E 101-42500-381		Electric Utilities	\$36.00		5452511 Lake Rd Siren
E 101-43100-387		Street Lighting-Electricity	\$95.00		6400610 Co Side Addn St Lights
E 601-49440-381		Electric Utilities	\$243.00		10052700 Walnut Cir Water Tow
E 101-43100-387		Street Lighting-Electricity	\$43.00		10232500 Co Rd140/H23 St Light
E 101-43100-387		Street Lighting-Electricity	\$50.00		10232600 Co Rd8/H23 St Lights
E 602-49490-381		Electric Utilities	\$95.00		10405800 Co Rd 8 Lift Station
E 602-49490-381		Electric Utilities	\$166.00		10405900 Co Rd 6 Lift Station
E 602-49490-381		Electric Utilities	\$272.00		10406000 Prairie Dr Lift Stati
E 602-49490-381		Electric Utilities	\$81.00		10440600 Pleasant Lk Lift Stat
E 601-49440-382		PL LK Electric Utilities	\$40.50		10543000 79th Ave Pump House
E 601-49440-382		PL LK Electric Utilities	\$394.00		10516700 Pleasant Rd Pump Hous
E 101-43100-387		Street Lighting-Electricity	\$156.00		10453000 St Lights Prairie Dr
E 101-43100-387		Street Lighting-Electricity	\$70.00		10549600 St Lights Brentwood
E 101-43100-387		Street Lighting-Electricity	\$50.00		11633200 St Lights Co Rd6/Hw23
E 101-42500-381		Electric Utilities	\$27.00		12490100 9102 220th St Siren
E 602-49490-381		Electric Utilities	\$35.00		12505300 1340 Prairie Dr Flume Meter
		Total	\$1,853.50		
20494	03/12/21	WEST CENTRAL SANITATION, INC			
E 101-42200-384		Refuse/Garbage Disposal	\$24.11		GARBAGE-FIRE HALL
E 101-45122-384		Refuse/Garbage Disposal	\$13.43		GARBAGE-PLEASANT LK
E 101-41000-384		Refuse/Garbage Disposal	\$23.00		GARBAGE-CITY HALL
E 101-43100-384		Refuse/Garbage Disposal	\$90.20		GARBAGE-PUB WKS DPT
		Total	\$150.74		
20495	03/19/21	ALEX AIR APPARATUS INC			
E 101-42200-540		Machinery & Equipment	\$1,226.19	43272	Drop Tank Unit 1
		Total	\$1,226.19		
20496	03/19/21	AT & T MOBILITY			
E 101-43100-321		Telephone	\$80.47	3092021	WIRELESS PHONE
E 601-49440-321		Telephone	\$25.00	3092021	WIRELESS PHONE
E 602-49490-321		Telephone	\$25.00	3092021	WIRELESS PHONE
E 101-45122-321		Telephone	\$10.00	3092021	WIRELESS PHONE
E 602-49490-321		Telephone	\$30.68	3092021	GRINDERSTATION PHONE
		Total	\$171.15		
20497	03/19/21	CENTERPOINT ENERGY-MINNEGASCO			
E 601-49440-383		Gas Utilities	\$70.14		6109069-2 PMPHSE OTHMAR/MAPLE
E 101-43100-383		Gas Utilities	\$182.62		6109272-2 209 BRDWY-PUB WKS
E 601-49440-383		Gas Utilities	\$182.61		6109272-2 209 BRDWY-PUB WKS
E 602-49490-383		Gas Utilities	\$182.61		6109272-2 209 BRDWY-PUB WKS

CITY OF ROCKVILLE

***Check Detail Register©**

MARCH 2021

Check #	Check Date	Vendor Name	Amount	Invoice	Comment
E 601-49440-383		Gas Utilities	\$53.34		6110833-8 PUMPHSE @ WAL CIR
E 101-41000-383		Gas Utilities	\$35.19		6394888-9 UTIL-229 CITY HALL
E 101-41110-383		Gas Utilities	\$35.19		6394888-9 UTIL-229 CITY HALL
E 101-41800-383		Gas Utilities	\$35.19		6394888-9 UTIL-229 CITY HALL
E 101-43100-383		Gas Utilities	\$35.19		6394888-9 UTIL-229 CITY HALL
E 101-46300-383		Gas Utilities	\$35.19		6394888-9 UTIL-229 CITY HALL
E 601-49440-383		Gas Utilities	\$35.19		6394888-9 UTIL-229 CITY HALL
E 602-49490-383		Gas Utilities	\$35.19		6394888-9 UTIL-229 CITY HALL
E 101-42200-383		Gas Utilities	\$700.62		6436553-9 24001 FIRE HALL DR
Total			\$1,618.27		
20498	03/19/21	JOVANOVICH DEGE & ATHMANN			
E 101-42200-304		Legal Fees	\$2,147.00	20866	Fire Dept grant contract
E 101-41000-304		Legal Fees	\$19.00	20866	Fee Schedule
E 101-41110-304		Legal Fees	\$456.00	20866	Attend Council Meeting, resolution
E 601-49440-304		Legal Fees	\$1,843.00	20866	Stickney
E 101-42200-304		Legal Fees	\$38.00	20866	Fire Service Contract MP
E 101-41000-304		Legal Fees	\$646.00	20867	Harstad Travel Plaza Development (Reimb from Owner)
E 101-41000-304		Legal Fees	\$608.00	20867	Loves Improvement (Reim from Owner)
E 101-41000-304		Legal Fees	\$817.00	20867	Tax Abatement Agreement
Total			\$6,574.00		
20499	03/19/21	NORTH CENTRAL BUS & EQUIPMENT			
E 101-42200-220		Repair/Operating Expense	\$374.40		Liner strobe & seat belt
Total			\$374.40		
20500	03/19/21	STEARNS CO AUDITOR-TREASURER			
E 101-41000-310		Other Professional Servic	\$259.00		2021 Truth in taxation
E 309-47000-310		Other Professional Servic	\$55.60		2021 Special Assessment
E 215-43100-310		Other Professional Servic	\$6.80		2021 Special Assessment
E 101-41000-310		Other Professional Servic	\$1.60		2021 Special Assessment
E 602-49490-310		Other Professional Servic	\$24.00		2021 Special Assessment
E 601-49440-310		Other Professional Servic	\$6.00		2021 Special Assessment
Total			\$353.00		
20501	03/19/21	VISA			
E 101-42200-433		Dues and Subscriptions	\$98.00		EMT Testing
E 101-43100-210		Operating Expenses	\$723.07		Lights for the Shop
E 601-49440-322		Postage	\$39.66		Water Samples
E 101-43100-212		Gas & Oil	\$166.03		Unit 168 & Unit 3
E 101-45122-220		Repair/Operating Expense	\$698.22		Soccer nets
E 601-49440-221		PL LK/Lake Repair/operati	\$657.00		Heater & Ac Unit for Well 4 & 5
E 602-49490-331		Hotel,Meal,Prkg & Mileage	\$50.20		Stickney SIC Permit (Sue, Justin, Marty, Jerry & Bill)
E 101-41800-332		Training	\$70.00		Marty Membership Renewal MGFOA
E 101-42200-200		Office Supplies	\$86.92		Ink for Printer, paper, pads, cups, can liners
E 101-41000-200		Office Supplies	\$11.13		paper, pads, cups, can liners
E 101-43100-200		Office Supplies	\$11.13		paper, pads, cups, can liners
E 601-49440-200		Office Supplies	\$11.13		paper, pads, cups, can liners
E 602-49490-200		Office Supplies	\$11.13		paper, pads, cups, can liners

CITY OF ROCKVILLE

***Check Detail Register©**

MARCH 2021

Check #	Check Date	Vendor Name	Amount	Invoice	Comment
E 101-41110-200		Office Supplies	\$11.13		paper, pads, cups, can liners
E 101-46300-200		Office Supplies	\$11.13		paper, pads, cups, can liners
E 101-42200-209		Cleaning Supplies	\$4.28		Gloves
E 101-41000-209		Cleaning Supplies	\$4.28		Gloves
E 101-43100-209		Cleaning Supplies	\$4.28		Gloves
E 601-49440-209		Cleaning Supplies	\$4.28		Gloves
E 602-49490-209		Cleaning Supplies	\$4.28		Gloves
E 101-41110-209		Cleaning Supplies	\$4.28		Gloves
E 101-46300-209		Cleaning Supplies	\$4.28		Gloves
		Total	\$2,685.84		
20502	03/24/21	AMERICAN SOLUTIONS FOR BUSINES			
E 101-41000-200		Office Supplies	\$15.76	5232206	Laser Checks
E 101-41110-200		Office Supplies	\$15.79	5232206	Laser Checks
E 101-41800-200		Office Supplies	\$15.79	5232206	Laser Checks
E 101-42200-200		Office Supplies	\$15.79	5232206	Laser Checks
E 101-42500-200		Office Supplies	\$15.79	5232206	Laser Checks
E 101-43100-200		Office Supplies	\$15.79	5232206	Laser Checks
E 101-45122-210		Operating Expenses	\$15.79	5232206	Laser Checks
E 601-49440-200		Office Supplies	\$15.79	5232206	Laser Checks
E 602-49490-200		Office Supplies	\$15.79	5232206	Laser Checks
		Total	\$142.08		
20503	03/24/21	BATTERIES PLUS			
E 602-49490-220		Repair/Operating Expense	\$12.95	37668803	Battery for Dialer @ Main Lift station
		Total	\$12.95		
20504	03/24/21	CENTRACARE HEALTH			
E 101-42200-292		Health Srvc/Pre Employ	\$314.00		Preemployment Hudson Musielewicz
		Total	\$314.00		
20505	03/24/21	CENTRAL HYDRAULICS			
E 101-43100-320		Ditch Mowing	\$14.78	115064	Brush Mower
		Total	\$14.78		
20506	03/24/21	CENTURYLINK			
E 101-42200-321		Telephone	\$86.22		251-0072 Fire Dept
E 601-49440-321		Telephone	\$41.28		251-1664 SCDA System
E 602-49490-321		Telephone	\$41.28		251-1664 SCDA System
E 601-49440-321		Telephone	\$56.11		251-2120 Well house 3
E 101-41000-321		Telephone	\$39.88		251-5836 City Hall
E 101-41110-321		Telephone	\$39.88		251-5836 City Hall
E 101-43100-321		Telephone	\$39.88		251-5836 City Hall
E 101-46300-321		Telephone	\$39.88		251-5836 City Hall
E 601-49440-321		Telephone	\$39.88		251-5836 City Hall
E 602-49490-321		Telephone	\$39.88		251-5836 City Hall
E 602-49490-321		Telephone	\$59.55		259-1473 Sewer
E 602-49490-321		Telephone	\$69.65		685-4204 Sewer
E 602-49490-321		Telephone	\$205.50		612-E16-2655 Sewer
		Total	\$798.87		

CITY OF ROCKVILLE

***Check Detail Register©**

MARCH 2021

Check #	Check Date	Vendor Name	Amount	Invoice	Comment
20507	03/24/21	DAVID DROWN ASSOCIATES, INC			
E 101-41000-310		Other Professional Servic	\$3,600.00	4937	Tax Abatement Fee
		Total	\$3,600.00		
20508	03/24/21	MARCO FINANCING, INC (LEASE)			
E 101-41000-413		Copier/Printer Lease	\$110.30	438646473	COPIER/LEASE
E 101-41110-413		Copier/Printer Lease	\$55.00	438646473	COPIER/LEASE
E 101-42200-413		Copier/Printer Lease	\$30.00	438646473	COPIER/LEASE
E 101-42500-413		Copier/Printer Lease	\$20.00	438646473	COPIER/LEASE
E 101-43100-413		Copier/Printer Lease	\$52.00	438646473	COPIER/LEASE
E 101-45122-413		Copier/Printer Lease	\$10.00	438646473	COPIER/LEASE
E 101-46300-413		Copier/Printer Lease	\$55.00	438646473	COPIER/LEASE
E 601-49440-413		Copier/Printer Lease	\$65.00	438646473	COPIER/LEASE
E 602-49490-413		Copier/Printer Lease	\$75.00	438646473	COPIER/LEASE
		Total	\$472.30		
20509	03/24/21	MENARDS			
E 602-49490-220		Repair/Operating Expense	\$109.00	61812	Cast Iron sump pump Main Liftstation
		Total	\$109.00		
20510	03/24/21	NELSON ELECTRIC MOTOR REP INC			
E 602-49490-288		Lk Sewer Lift Station	\$1,375.00	1515	Voigts Liftstation - removed soft starts & installed new motor starter
E 602-49490-220		Repair/Operating Expense	\$450.00	1522	Main Liftstation- Pulled Pump # 2 checked the controls
E 602-49490-220		Repair/Operating Expense	\$795.00	1523	Main Liftstation-scraped grease off the walls pulled pump 1 removed debris from impeller, installed a loaner pump #2
		Total	\$2,620.00		
20511	03/24/21	RIDGEWATER COLLEGE			
E 101-42200-332		Training	\$850.00	238043	EMR Refresher/CPR Course 02.08.21
		Total	\$850.00		
20512	03/24/21	STEARNS CO AUDITOR-TREASURER			
E 101-45122-434		Property Taxes Payable	\$678.00		1st & 2nd76.41615.0800 Eagle Park Property Taxes
		Total	\$678.00		
20513	03/24/21	STEARNS CO RECORDER OFFICE			
E 101-46300-429		Recording of Legal Docum	\$46.00		76.42240.0200 EICHI Granting CUP
		Total	\$46.00		
20514	03/24/21	THEIN WELL			
E 601-49440-220		Repair/Operating Expense	\$232.50	7395	Annual Inspection on Pumps & Wells on 03.12.21
E 601-49440-221		PL LK/Lake Repair/operati	\$232.50	7395	Annual Inspection on Pumps & Wells on 03.12.21
		Total	\$465.00		
20515	03/24/21	TOM KRAEMER, INC			
E 101-43100-384		Refuse/Garbage Disposal	\$36.00	123931	Tire Car w/o rim
		Total	\$36.00		

CITY OF ROCKVILLE

04/07/21 12:41 PM

Page 9

***Check Detail Register©**

MARCH 2021

Check #	Check Date	Vendor Name	Amount	Invoice	Comment
20516	03/24/21	USA BLUEBOOK			
E 601-49440-220		Repair/Operating Expense	\$196.92	520779	Water Sampling - Hach, colorimeter tubes, flouride reagent
E 601-49440-221		PL LK/Lake Repair/operati	\$196.92	520779	Water Sampling - Hach, colorimeter tubes, flouride reagent
		Total	\$393.84		
20517	03/31/21	COLDSRING			
E 101-43100-338		Crushing/Gravel Purchase	\$113.47	102-25-0001	Crush Granite Hubert Ln
		Total	\$113.47		
20518	03/31/21	GRANITE ELECTRONICS			
E 101-42200-218		Radio & Communication	\$835.54	154006912-1	Unit 14 Install New Radio
		Total	\$835.54		
20519	03/31/21	HAWKINS, INC			
E 601-49440-217		PL LK Chemicals/Chem P	\$10.00		Chlorine Cylinder
E 601-49440-216		Chemicals/Chem Products	\$10.00		Chlorine Cylinder
		Total	\$20.00		
20520	03/31/21	LYNN PLUMSKI			
E 101-41000-106		Cleaning Person	\$9.38		CITY HALL
E 101-41110-106		Cleaning Person	\$9.38		CITY HALL
E 101-41800-106		Cleaning Person	\$9.38		CITY HALL
E 101-42200-106		Cleaning Person	\$84.37		CITY HALL/FIRE HALL
E 101-43100-106		Cleaning Person	\$9.38		CITY HALL
E 101-46300-106		Cleaning Person	\$9.37		CITY HALL
E 601-49440-106		Cleaning Person	\$9.37		CITY HALL
E 602-49490-106		Cleaning Person	\$9.37		CITY HALL
		Total	\$150.00		
20521	03/31/21	NELSON ELECTRIC MOTOR REP INC			
E 602-49490-220		Repair/Operating Expense	\$2,393.50	1531	Main Lift Station install pump 2 after rebuilding, repair volute on pump #1
		Total	\$2,393.50		
20522	03/31/21	PINEVIEW CONSTRUCTION INC			
E 101-43100-220		Repair/Operating Expense	\$280.00		Repair shed Gavin Schmitt
		Total	\$280.00		
20523	03/31/21	USABLE LIFE			
G 101-21709		Short/Long-Term Disability	\$64.96		EMPLOYEE PORTION
E 101-41000-134		Employer Paid Life Insura	\$29.60		LTD/STD
E 101-41000-135		Empl r Pd Short/Long Ter	\$259.95		LTD/STD
		Total	\$354.51		
20524	03/31/21	XCEL ENERGY			
E 101-45122-381		Electric Utilities	\$42.94		1001 OTHMAR LN
E 101-43100-387		Street Lighting-Electricity	\$703.97		STREETLGHTS
E 601-49440-381		Electric Utilities	\$74.20		209 BRDWDY & 562 CHESTNUT
E 602-49490-381		Electric Utilities	\$74.20		209 BRDWDY & 562 CHESTNUT
E 101-43100-381		Electric Utilities	\$74.20		209 BRDWDY & 562 CHESTNUT

CITY OF ROCKVILLE

***Check Detail Register©**

MARCH 2021

Check #	Check Date	Vendor Name	Amount	Invoice	Comment
E 602-49490-381		Electric Utilities	\$510.50		398 BROADWAY ST
E 601-49440-381		Electric Utilities	\$372.20		423 MAPLE ST & 560 CHESTNUT
E 101-45122-381		Electric Utilities	\$60.68		1000 BRDWDY BALLPK BALL PRG
E 101-41000-381		Electric Utilities	\$39.53		229 BROADWAY
E 101-41800-381		Electric Utilities	\$39.52		229 BROADWAY
E 101-43100-381		Electric Utilities	\$39.52		229 BROADWAY
E 101-46300-381		Electric Utilities	\$39.52		229 BROADWAY
E 601-49440-381		Electric Utilities	\$39.52		229 BROADWAY
E 602-49490-381		Electric Utilities	\$39.52		229 BROADWAY
E 101-41110-381		Electric Utilities	\$39.52		229 BROADWAY
E 101-42200-381		Electric Utilities	\$458.77		24001 FIRE HALL DR
		Total	\$2,648.31		
		10600 GCB Checkbook-MM	\$74,815.88		

Fund Summary

10600 GCB Checkbook-MM	
101 GENERAL FUND	\$57,172.30
215 ROAD MAINTENANCE FUND	\$6.80
309 LAKES SEWER PROJECT BOND 2004	\$55.60
601 WATER FUND	\$6,377.41
602 SEWER FUND	\$11,203.77
	\$74,815.88

CITY OF ROCKVILLE
Exp Detail Council MMB jn

Check Nbr	Check/Receipt Date	Search Name	Amount	Comments	Act Code	OBJ Descr
FUND 101 GENERAL FUND						
DEPT						
001566	03/10/21	PERA	\$1,762.07	RETIRE CONTR-	101-21704	
001567	03/10/21	MN REVENUE	\$504.54	STATE TAX W/H-	101-21702	
001568	03/10/21	EFTPS-ELECTRONIC FED TAX PMT	\$1,533.76	FEDERAL W/H -	101-21701	
001568	03/10/21	EFTPS-ELECTRONIC FED TAX PMT	\$2,028.90	FICA/MEDICARE -	101-21703	
001571	03/24/21	PERA	\$1,762.07	RETIRE CONTR-	101-21704	
001572	03/24/21	MN REVENUE	\$532.47	STATE TAX W/H-	101-21702	
001573	03/24/21	EFTPS-ELECTRONIC FED TAX PMT	\$1,603.35	FEDERAL W/H -	101-21701	
001573	03/24/21	EFTPS-ELECTRONIC FED TAX PMT	\$2,097.32	FICA/MEDICARE -	101-21703	
020478	03/03/21	RIVER POWER & EQUIPMENT INC	\$327.00	45122-220 Repair Rear glass TYM tractor	101-20200	
020480	03/03/21	USABLE LIFE	\$64.96	EMPLOYEE PORTION	101-21709	
020485	03/12/21	BLUE CROSS BLUE SHIELD OF MN	\$289.66	EMPLOYEE PORTION HEALTH INS.	101-21705	
020485	03/12/21	BLUE CROSS BLUE SHIELD OF MN	\$1,158.63	EMPLOYER PD HEALTH INS.	101-21706	
020523	03/31/21	USABLE LIFE	\$64.96	EMPLOYEE PORTION	101-21709	
			\$13,729.69			
DEPT						
DEPT 41000 General Government (GENERAL)						
001569	03/10/21	PAYMENT SERVICE NETWORK	\$1.23	Monthly Credit Card fee	101-41000-210	Operating Expenses
001570	03/10/21	CITY OF ROCKVILLE	\$44.54	WATER/SEWER CH	101-41000-210	
020469	03/03/21	BOLTON & MENK INC	\$355.00	Loves Travel Plaza Site Improvements (Reimb)	101-41000-303	Engineering Fees
020469	03/03/21	BOLTON & MENK INC	\$1,350.00	Harstad Travel Plaza Development (Reimb)	101-41000-303	
020475	03/03/21	LYNN PLUMSKI	\$9.38	CITY HALL	101-41000-106	Cleaning Person
020480	03/03/21	USABLE LIFE	\$29.60	LTD/STD	101-41000-134	Employer Paid Life Insurance
020480	03/03/21	USABLE LIFE	\$259.95	LTD/STD	101-41000-135	Empl r Pd Short/Long Term Ins
020481	03/03/21	XCEL ENERGY	\$51.21	229 BROADWAY	101-41000-381	Electric Utilities
020483	03/12/21	ARAMARK	\$28.08	RENTAL OF RUGS/MOPS-CITY HALL	101-41000-209	Cleaning Supplies
020487	03/12/21	COLD SPRING RECORD INC	\$29.51	envelopes, Fees and Charges	101-41000-340	Advertising/Printing/Publishin
020491	03/12/21	LYNN PLUMSKI	\$9.38	CITY HALL	101-41000-106	Cleaning Person
020492	03/12/21	MIDCO	\$9.48	CITY HALL	101-41000-323	Internet/E-mail/Web Site
020494	03/12/21	WEST CENTRAL SANITATION, INC	\$23.00	GARBAGE-CITY HALL	101-41000-384	Refuse/Garbage Disposal
020497	03/19/21	CENTER POINT ENERGY-MINNEGASCO	\$35.19	6394888-9 UTIL-229 CITY HALL	101-41000-383	Gas Utilities
020498	03/19/21	JOVANOVIH DEGE & ATHMANN	\$608.00	Loves Improvement (Reim from Owner)	101-41000-304	Legal Fees
020498	03/19/21	JOVANOVIH DEGE & ATHMANN	\$646.00	Harstad Travel Plaza Development (Reimb from Owner)	101-41000-304	
020498	03/19/21	JOVANOVIH DEGE & ATHMANN	\$19.00	Fee Schedule	101-41000-304	
020498	03/19/21	JOVANOVIH DEGE & ATHMANN	\$817.00	Tax Abatement Agreement	101-41000-304	
020500	03/19/21	STEARNS CO AUDITOR-TREASURER	\$1.60	2021 Special Assessment	101-41000-310	Other Professional Services
020500	03/19/21	STEARNS CO AUDITOR-TREASURER	\$259.00	2021 Truth in taxation	101-41000-310	

CITY OF ROCKVILLE
Exp Detail Council MMB jn

Check Nbr	Check/Receipt Date	Search Name	Amount	Comments	Act Code	OBJ Descr
020501	03/19/21	VISA	\$11.13	paper, pads, cups, can liners	101-41000-200	Office Supplies
020501	03/19/21	VISA	\$4.28	Gloves	101-41000-209	Cleaning Supplies
020502	03/24/21	AMERICAN SOLUTIONS FOR BUSINES	\$15.76	Laser Checks	101-41000-200	Office Supplies
020506	03/24/21	CENTURYLINK	\$39.88	251-5836 City Hall	101-41000-321	Telephone
020507	03/24/21	DAVID DROWN ASSOCIATES, INC	\$3,600.00	Tax Abatement Fee	101-41000-310	Other Professional Services
020508	03/24/21	MARCO FINANCING, INC (LEASE)	\$110.30	COPIER/LEASE	101-41000-413	Copier/Printer Lease
020520	03/31/21	LYNN PLUMSKI	\$9.38	CITY HALL	101-41000-106	Cleaning Person
020523	03/31/21	USABLE LIFE	\$29.60	LTD/STD	101-41000-134	Employer Paid Life Insurance
020523	03/31/21	USABLE LIFE	\$259.95	LTD/STD	101-41000-135	Empl r Pd Short/Long Term Ins
020524	03/31/21	XCEL ENERGY	\$39.53	229 BROADWAY	101-41000-381	Electric Utilities
DEPT 41000 General Government (GENERAL)			\$8,705.96			
DEPT 41110 Council/Mayor/Boards						
001570	03/10/21	CITY OF ROCKVILLE	\$5.00	WATER/SEWER CH	101-41110-210	Operating Expenses
020475	03/03/21	LYNN PLUMSKI	\$9.38	CITY HALL	101-41110-106	Cleaning Person
020481	03/03/21	XCEL ENERGY	\$51.22	229 BROADWAY	101-41110-381	Electric Utilities
020483	03/12/21	ARAMARK	\$9.00	RENTAL OF RUGS/MOPS-CITY HALL	101-41110-209	Cleaning Supplies
020488	03/12/21	GOV OFFICE LLC	\$50.00	Jerry T email	101-41110-323	Internet/E-mail/Web Site
020491	03/12/21	LYNN PLUMSKI	\$9.38	CITY HALL	101-41110-106	Cleaning Person
020492	03/12/21	MIDCO	\$9.44	CITY HALL	101-41110-323	Internet/E-mail/Web Site
020497	03/19/21	CENTER POINT ENERGY-MINNEGASCO	\$35.19	6394888-9 UTIL-229 CITY HALL	101-41110-383	Gas Utilities
020498	03/19/21	JOVANOVICH DEGE & ATHMANN	\$456.00	Attend Council Meeting, resolution	101-41110-304	Legal Fees
020501	03/19/21	VISA	\$11.13	paper, pads, cups, can liners	101-41110-200	Office Supplies
020501	03/19/21	VISA	\$4.28	Gloves	101-41110-209	Cleaning Supplies
020502	03/24/21	AMERICAN SOLUTIONS FOR BUSINES	\$15.79	Laser Checks	101-41110-200	Office Supplies
020506	03/24/21	CENTURYLINK	\$39.88	251-5836 City Hall	101-41110-321	Telephone
020508	03/24/21	MARCO FINANCING, INC (LEASE)	\$55.00	COPIER/LEASE	101-41110-413	Copier/Printer Lease
020520	03/31/21	LYNN PLUMSKI	\$9.38	CITY HALL	101-41110-106	Cleaning Person
020524	03/31/21	XCEL ENERGY	\$39.52	229 BROADWAY	101-41110-381	Electric Utilities
DEPT 41110 Council/Mayor/Boards			\$809.59			
DEPT 41800 City Administration						
001570	03/10/21	CITY OF ROCKVILLE	\$20.00	WATER/SEWER CH	101-41800-210	Operating Expenses
020475	03/03/21	LYNN PLUMSKI	\$9.38	CITY HALL	101-41800-106	Cleaning Person
020481	03/03/21	XCEL ENERGY	\$51.22	229 BROADWAY	101-41800-381	Electric Utilities
020491	03/12/21	LYNN PLUMSKI	\$9.38	CITY HALL	101-41800-106	Cleaning Person
020492	03/12/21	MIDCO	\$9.44	CITY HALL	101-41800-323	Internet/E-mail/Web Site
020497	03/19/21	CENTER POINT ENERGY-MINNEGASCO	\$35.19	6394888-9 UTIL-229 CITY HALL	101-41800-383	Gas Utilities
020501	03/19/21	VISA	\$70.00	Marty Membership Renewal MGFOA	101-41800-332	Training
020502	03/24/21	AMERICAN SOLUTIONS FOR BUSINES	\$15.79	Laser Checks	101-41800-200	Office Supplies

CITY OF ROCKVILLE
Exp Detail Council MMB jn

Check Nbr	Check/Receipt Date	Search Name	Amount	Comments	Act Code	OBJ Descr
020520	03/31/21	LYNN PLUMSKI	\$9.38	CITY HALL	101-41800-106	Cleaning Person
020524	03/31/21	XCEL ENERGY	\$39.52	229 BROADWAY	101-41800-381	Electric Utilities
DEPT 41800 City Administration			\$269.30			
DEPT 42200 Fire Protection						
020456	02/17/21	NIEL MEIERHOFER	-\$550.00	FEMA SCBA grant application & narrative for air system	101-42200-310	Other Professional Services
020475	03/03/21	LYNN PLUMSKI	\$78.12	CITY HALL/FIRE HALL	101-42200-106	Cleaning Person
020481	03/03/21	XCEL ENERGY	\$459.99	24001 FIRE HALL DR	101-42200-381	Electric Utilities
020482	03/12/21	ADVANCE AUTO PARTS	\$320.35	Unit 1 wire connectors, clips, conductors, elect taple, Trail	101-42200-220	Repair/Operating Expense
020483	03/12/21	ARAMARK	\$9.00	RENTAL OF RUGS/MOPS-CITY HALL	101-42200-209	Cleaning Supplies
020484	03/12/21	AT & T MOBILITY	\$76.46	FirstNet Fire Dept wireless	101-42200-321	Telephone
020486	03/12/21	CENTRAL MCGOWAN, INC	\$25.58	MEDICAL OXYGEN/RENT-FIRE DEPT	101-42200-219	Fire Rescue Supplies
020487	03/12/21	COLD SPRING RECORD INC	\$19.67	envelopes	101-42200-340	Advertising/Printing/Publishin
020489	03/12/21	GUARDIAN FLEET SAFETY	\$389.50	Lightbar for Suburban	101-42200-220	Repair/Operating Expense
020491	03/12/21	LYNN PLUMSKI	\$78.12	CITY HALL/FIRE HALL	101-42200-106	Cleaning Person
020492	03/12/21	MIDCO	\$75.00	FIRE HALL	101-42200-323	Internet/E-mail/Web Site
020494	03/12/21	WEST CENTRAL SANITATION, INC	\$24.11	GARBAGE-FIRE HALL	101-42200-384	Refuse/Garbage Disposal
020495	03/19/21	ALEX AIR APPARATUS INC	\$1,226.19	Drop Tank Unit 1	101-42200-540	Machinery & Equipment
020497	03/19/21	CENTER POINT ENERGY-MINNEGASCO	\$700.62	6436553-9 24001 FIRE HALL DR	101-42200-383	Gas Utilities
020498	03/19/21	JOVANOVIH DEGE & ATHMANN	\$38.00	Fire Service Contract MP	101-42200-304	Legal Fees
020498	03/19/21	JOVANOVIH DEGE & ATHMANN	\$2,147.00	Fire Dept grant contract	101-42200-304	
020499	03/19/21	NORTH CENTRAL	\$374.40	Liner strobe & seat belt	101-42200-220	Repair/Operating Expense
020501	03/19/21	VISA	\$86.92	Ink for Printer, paper, pads, cups, can liners	101-42200-200	Office Supplies
020501	03/19/21	VISA	\$4.28	Gloves	101-42200-209	Cleaning Supplies
020501	03/19/21	VISA	\$98.00	EMT Testing	101-42200-433	Dues and Subscriptions
020502	03/24/21	AMERICAN SOLUTIONS FOR BUSINES	\$15.79	Laser Checks	101-42200-200	Office Supplies
020504	03/24/21	CENTRACARE HEALTH	\$314.00	Preemployment Hudson Musielewicz	101-42200-292	Health Svc/Pre Employment
020506	03/24/21	CENTURYLINK	\$86.22	251-0072 Fire Dept	101-42200-321	Telephone
020508	03/24/21	MARCO FINANCING, INC (LEASE)	\$30.00	COPIER/LEASE	101-42200-413	Copier/Printer Lease
020511	03/24/21	RIDGEWATER COLLEGE BUS OFFICE	\$850.00	EMR Refresher/CPR Course 02.08.21	101-42200-332	Training
020518	03/31/21	GRANITE ELECTRONICS,INC	\$835.54	Unit 14 Install New Radio	101-42200-218	Radio & Communication
020520	03/31/21	LYNN PLUMSKI	\$84.37	CITY HALL/FIRE HALL	101-42200-106	Cleaning Person
020524	03/31/21	XCEL ENERGY	\$458.77	24001 FIRE HALL DR	101-42200-381	Electric Utilities
DEPT 42200 Fire Protection			\$8,356.00			
DEPT 42500 Emergency Management						
020470	03/03/21	DELTA ELECTRIC	\$95.00	Took apart old siren @ school not repairable	101-42500-220	Repair/Operating Expense
020492	03/12/21	MIDCO	\$9.44	CITY HALL	101-42500-323	Internet/E-mail/Web Site
020493	03/12/21	STEARNS ELECTRIC ASOC INC	\$36.00	5452511 Lake Rd Siren	101-42500-381	Electric Utilities
020493	03/12/21	STEARNS ELECTRIC ASOC INC	\$27.00	12490100 9102 220th St Siren	101-42500-381	

CITY OF ROCKVILLE
Exp Detail Council MMB jn

Check Nbr	Check/Receipt Date	Search Name	Amount	Comments	Act Code	OBJ Descr
020502	03/24/21	AMERICAN SOLUTIONS FOR BUSINES	\$15.79	Laser Checks	101-42500-200	Office Supplies
020508	03/24/21	MARCO FINANCING, INC (LEASE)	\$20.00	COPIER/LEASE	101-42500-413	Copier/Printer Lease
DEPT 42500 Emergency Management			\$203.23			
DEPT 43100 Hwys, Streets, & Roads						
001570	03/10/21	CITY OF ROCKVILLE	\$5.00	WATER/SEWER CH	101-43100-210	Operating Expenses
001570	03/10/21	CITY OF ROCKVILLE	\$65.11	WATER/SEWER MTSHP	101-43100-210	
020469	03/03/21	BOLTON & MENK INC	\$17,425.75	Public Works Building (Project Management, Meetings, De	101-43100-303	Engineering Fees
020474	03/03/21	KIESS BROS	\$283.28	Fuel Streets	101-43100-212	Gas & Oil
020475	03/03/21	LYNN PLUMSKI	\$9.38	CITY HALL	101-43100-106	Cleaning Person
020476	03/03/21	MIDWAY IRON & METAL CO INC	\$53.00	Unit 5 repair of the wing/arm on plow truck	101-43100-220	Repair/Operating Expense
020479	03/03/21	TOM KRAEMER, INC	\$46.25	Old shop bulbs	101-43100-384	Refuse/Garbage Disposal
020481	03/03/21	XCEL ENERGY	\$110.33	209 BRDWY & 562 CHESTNUT	101-43100-381	Electric Utilities
020481	03/03/21	XCEL ENERGY	\$51.22	229 BROADWAY	101-43100-381	
020481	03/03/21	XCEL ENERGY	\$713.52	STREETLGHTS	101-43100-387	Street Lighting-Electricity
020482	03/12/21	ADVANCE AUTO PARTS	\$15.57	Unit 3 Lock Clyinder	101-43100-220	Repair/Operating Expense
020482	03/12/21	ADVANCE AUTO PARTS	\$108.79	Water pump unit 3	101-43100-220	
020482	03/12/21	ADVANCE AUTO PARTS	\$32.28	Unit 3 Antifrz	101-43100-220	
020483	03/12/21	ARAMARK	\$9.00	RENTAL OF RUGS/MOPS-CITY HALL	101-43100-209	Cleaning Supplies
020487	03/12/21	COLD SPRING RECORD INC	\$159.92	Advertise for Bids (PW building), envelopes	101-43100-340	Advertising/Printing/Publishin
020491	03/12/21	LYNN PLUMSKI	\$9.38	CITY HALL	101-43100-106	Cleaning Person
020492	03/12/21	MIDCO	\$9.44	CITY HALL	101-43100-323	Internet/E-mail/Web Site
020493	03/12/21	STEARNS ELECTRIC ASOC INC	\$43.00	10232500 Co Rd140/H23 St Light	101-43100-387	Street Lighting-Electricity
020493	03/12/21	STEARNS ELECTRIC ASOC INC	\$95.00	6400610 Co Side Addn St Lights	101-43100-387	
020493	03/12/21	STEARNS ELECTRIC ASOC INC	\$50.00	10232600 Co Rd8/H23 St Lights	101-43100-387	
020493	03/12/21	STEARNS ELECTRIC ASOC INC	\$50.00	11633200 St Lights Co Rd6/Hw23	101-43100-387	
020493	03/12/21	STEARNS ELECTRIC ASOC INC	\$70.00	10549600 St Lights Brentwood	101-43100-387	
020493	03/12/21	STEARNS ELECTRIC ASOC INC	\$156.00	10453000 St Lights Prairie Dr	101-43100-387	
020494	03/12/21	WEST CENTRAL SANITATION, INC	\$90.20	GARBAGE-PUB WKS DPT	101-43100-384	Refuse/Garbage Disposal
020496	03/19/21	AT & T MOBILITY	\$80.47	WIRELESS PHONE	101-43100-321	Telephone
020497	03/19/21	CENTER POINT ENERGY-MINNEGASCO	\$182.62	6109272-2 209 BRDWY-PUB WKS	101-43100-383	Gas Utilities
020497	03/19/21	CENTER POINT ENERGY-MINNEGASCO	\$35.19	6394888-9 UTIL-229 CITY HALL	101-43100-383	
020501	03/19/21	VISA	\$11.13	paper, pads, cups, can liners	101-43100-200	Office Supplies
020501	03/19/21	VISA	\$4.28	Gloves	101-43100-209	Cleaning Supplies
020501	03/19/21	VISA	\$723.07	Lights for the Shop	101-43100-210	Operating Expenses
020501	03/19/21	VISA	\$166.03	Unit 168 & Unit 3	101-43100-212	Gas & Oil
020502	03/24/21	AMERICAN SOLUTIONS FOR BUSINES	\$15.79	Laser Checks	101-43100-200	Office Supplies
020505	03/24/21	CENTRAL HYDRAULICS	\$14.78	Brush Mower	101-43100-320	Ditch Mowing
020506	03/24/21	CENTURYLINK	\$39.88	251-5836 City Hall	101-43100-321	Telephone

CITY OF ROCKVILLE
Exp Detail Council MMB jn

Check Nbr	Check/Receipt Date	Search Name	Amount	Comments	Act Code	OBJ Descr
020508	03/24/21	MARCO FINANCING, INC (LEASE)	\$52.00	COPIER/LEASE	101-43100-413	Copier/Printer Lease
020515	03/24/21	TOM KRAEMER, INC	\$36.00	Tire Car w/o rim	101-43100-384	Refuse/Garbage Disposal
020517	03/31/21	COLDSPRING	\$113.47	Crush Granite Hubert Ln	101-43100-338	Crushing/Gravel Purchase
020520	03/31/21	LYNN PLUMSKI	\$9.38	CITY HALL	101-43100-106	Cleaning Person
020522	03/31/21	PINEVIEW CONSTRUCTION INC	\$280.00	Repair shed Gavin Schmitt	101-43100-220	Repair/Operating Expense
020524	03/31/21	XCEL ENERGY	\$39.52	229 BROADWAY	101-43100-381	Electric Utilities
020524	03/31/21	XCEL ENERGY	\$74.20	209 BRDWY & 562 CHESTNUT	101-43100-381	
020524	03/31/21	XCEL ENERGY	\$703.97	STREETLGHTS	101-43100-387	Street Lighting-Electricity
DEPT 43100 Hwys, Streets, & Roads			\$22,243.20			
DEPT 45122 Parks & Recreation						
001570	03/10/21	CITY OF ROCKVILLE	\$48.62	WATER/SEWER SOFTBALL PARK	101-45122-210	Operating Expenses
020474	03/03/21	KIESS BROS	\$22.01	Fuel Parks	101-45122-212	Gas & Oil
020481	03/03/21	XCEL ENERGY	\$60.74	1000 BRDWY BALLPK BALL PRG	101-45122-381	Electric Utilities
020481	03/03/21	XCEL ENERGY	\$42.28	1001 OTHMAR LN	101-45122-381	
020492	03/12/21	MIDCO	\$9.44	CITY HALL	101-45122-323	Internet/E-mail/Web Site
020494	03/12/21	WEST CENTRAL SANITATION, INC	\$13.43	GARBAGE-PLEASANT LK	101-45122-384	Refuse/Garbage Disposal
020496	03/19/21	AT & T MOBILITY	\$10.00	WIRELESS PHONE	101-45122-321	Telephone
020501	03/19/21	VISA	\$698.22	Soccer nets	101-45122-220	Repair/Operating Expense
020502	03/24/21	AMERICAN SOLUTIONS FOR BUSINES	\$15.79	Laser Checks	101-45122-210	Operating Expenses
020508	03/24/21	MARCO FINANCING, INC (LEASE)	\$10.00	COPIER/LEASE	101-45122-413	Copier/Printer Lease
020512	03/24/21	STEARNS CO AUDITOR-TREASURER	\$678.00	1st & 2nd76.41615.0800 Eagle Park Property Taxes	101-45122-434	Property Taxes Payable
020524	03/31/21	XCEL ENERGY	\$42.94	1001 OTHMAR LN	101-45122-381	Electric Utilities
020524	03/31/21	XCEL ENERGY	\$60.68	1000 BRDWY BALLPK BALL PRG	101-45122-381	
DEPT 45122 Parks & Recreation			\$1,712.15			
DEPT 46300 Planning and Zoning						
001569	03/10/21	PAYMENT SERVICE NETWORK	\$1.24	Monthly Credit Card fee	101-46300-210	Operating Expenses
001570	03/10/21	CITY OF ROCKVILLE	\$5.00	WATER/SEWER CH	101-46300-210	
020473	03/03/21	INSPECTRON INC.	\$689.41	Building Inspection & review	101-46300-305	Building Inspection Fees
020475	03/03/21	LYNN PLUMSKI	\$9.37	CITY HALL	101-46300-106	Cleaning Person
020481	03/03/21	XCEL ENERGY	\$51.22	229 BROADWAY	101-46300-381	Electric Utilities
020483	03/12/21	ARAMARK	\$9.00	RENTAL OF RUGS/MOPS-CITY HALL	101-46300-209	Cleaning Supplies
020487	03/12/21	COLD SPRING RECORD INC	\$118.76	Eichi Public Hearing, envelopes, Fees and charges	101-46300-340	Advertising/Printing/Publishin
020491	03/12/21	LYNN PLUMSKI	\$9.37	CITY HALL	101-46300-106	Cleaning Person
020492	03/12/21	MIDCO	\$9.44	CITY HALL	101-46300-323	Internet/E-mail/Web Site
020497	03/19/21	CENTER POINT ENERGY-MINNEGASCO	\$35.19	6394888-9 UTIL-229 CITY HALL	101-46300-383	Gas Utilities
020501	03/19/21	VISA	\$11.13	paper, pads, cups, can liners	101-46300-200	Office Supplies
020501	03/19/21	VISA	\$4.28	Gloves	101-46300-209	Cleaning Supplies
020506	03/24/21	CENTURYLINK	\$39.88	251-5836 City Hall	101-46300-321	Telephone

CITY OF ROCKVILLE
Exp Detail Council MMB jn

Check Nbr	Check/Receipt Date	Search Name	Amount	Comments	Act Code	OBJ Descr
020508	03/24/21	MARCO FINANCING, INC (LEASE)	\$55.00	COPIER/LEASE	101-46300-413	Copier/Printer Lease
020513	03/24/21	STEARNS CO RECORDER OFFICE	\$46.00	76.42240.0200 EICHI Granting CUP	101-46300-429	Recording of Legal Documents
020520	03/31/21	LYNN PLUMSKI	\$9.37	CITY HALL	101-46300-106	Cleaning Person
020524	03/31/21	XCEL ENERGY	\$39.52	229 BROADWAY	101-46300-381	Electric Utilities
DEPT 46300 Planning and Zoning			\$1,143.18			
FUND 101 GENERAL FUND			\$57,172.30			
FUND 215 ROAD MAINTENANCE FUND						
DEPT 43100 Hwys, Streets, & Roads						
020500	03/19/21	STEARNS CO AUDITOR-TREASURER	\$6.80	2021 Special Assessment	215-43100-310	Other Professional Services
DEPT 43100 Hwys, Streets, & Roads			\$6.80			
FUND 215 ROAD MAINTENANCE FUND			\$6.80			
FUND 309 LAKES SEWER PROJECT BOND 2004						
DEPT 47000 Debt Service (GENERAL)						
020500	03/19/21	STEARNS CO AUDITOR-TREASURER	\$55.60	2021 Special Assessment	309-47000-310	Other Professional Services
DEPT 47000 Debt Service (GENERAL)			\$55.60			
FUND 309 LAKES SEWER PROJECT BOND 2004			\$55.60			
FUND 601 WATER FUND						
DEPT						
020477	03/03/21	MN DEPT OF HEALTH	\$699.00	QTRLY MDH FEE TO STATE	601-20510	
DEPT			\$699.00			
DEPT 49440 Water-Administration						
001569	03/10/21	PAYMENT SERVICE NETWORK	\$1.24	Monthly Credit Card fee	601-49440-210	Operating Expenses
020471	03/03/21	GOPHER STATE ONE-CALL	\$3.37	LOCATE TICKETS-WTR DEPT	601-49440-291	Locates
020472	03/03/21	HAWKINS WTR TREATMENT GRP INC	\$10.00	Chlorine Cylinder	601-49440-216	Chemicals/Chem Products
020472	03/03/21	HAWKINS WTR TREATMENT GRP INC	\$10.00	Chlorine Cylinder	601-49440-217	PL LK Chemicals/Chem Products
020474	03/03/21	KIESS BROS	\$20.12	Fuel Water	601-49440-212	Gas & Oil
020475	03/03/21	LYNN PLUMSKI	\$9.37	CITY HALL	601-49440-106	Cleaning Person
020481	03/03/21	XCEL ENERGY	\$208.40	423 MAPLE ST & 560 CHESTNUT	601-49440-381	Electric Utilities
020481	03/03/21	XCEL ENERGY	\$51.22	229 BROADWAY	601-49440-381	
020481	03/03/21	XCEL ENERGY	\$110.33	209 BRDWDY & 562 CHESTNUT	601-49440-381	
020483	03/12/21	ARAMARK	\$9.00	RENTAL OF RUGS/MOPS-CITY HALL	601-49440-209	Cleaning Supplies
020487	03/12/21	COLD SPRING RECORD INC	\$29.51	envelopes, Fees and Charge	601-49440-340	Advertising/Printing/Publishin
020491	03/12/21	LYNN PLUMSKI	\$9.37	CITY HALL	601-49440-106	Cleaning Person
020492	03/12/21	MIDCO	\$9.44	CITY HALL	601-49440-323	Internet/E-mail/Web Site

CITY OF ROCKVILLE
Exp Detail Council MMB jn

Check Nbr	Check/Receipt Date	Search Name	Amount	Comments	Act Code	OBJ Descr
020493	03/12/21	STEARNS ELECTRIC ASOC INC	\$243.00	10052700 Walnut Cir Water Tow	601-49440-381	Electric Utilities
020493	03/12/21	STEARNS ELECTRIC ASOC INC	\$40.50	10543000 79th Ave Pump House	601-49440-382	PL LK Electric Utilities
020493	03/12/21	STEARNS ELECTRIC ASOC INC	\$394.00	10516700 Pleasant Rd Pump Hous	601-49440-382	
020496	03/19/21	AT & T MOBILITY	\$25.00	WIRELESS PHONE	601-49440-321	Telephone
020497	03/19/21	CENTER POINT ENERGY-MINNEGASCO	\$182.61	6109272-2 209 BRDWY-PUB WKS	601-49440-383	Gas Utilities
020497	03/19/21	CENTER POINT ENERGY-MINNEGASCO	\$35.19	6394888-9 UTIL-229 CITY HALL	601-49440-383	
020497	03/19/21	CENTER POINT ENERGY-MINNEGASCO	\$53.34	6110833-8 PUMPHSE @ WAL CIR	601-49440-383	
020497	03/19/21	CENTER POINT ENERGY-MINNEGASCO	\$70.14	6109069-2 PMPHSE OTHMAR/MAPLE	601-49440-383	
020498	03/19/21	JOVANOVIH DEGE & ATHMANN	\$1,843.00	Stickney	601-49440-304	Legal Fees
020500	03/19/21	STEARNS CO AUDITOR-TREASURER	\$6.00	2021 Special Assessment	601-49440-310	Other Professional Services
020501	03/19/21	VISA	\$11.13	paper, pads, cups, can liners	601-49440-200	Office Supplies
020501	03/19/21	VISA	\$4.28	Gloves	601-49440-209	Cleaning Supplies
020501	03/19/21	VISA	\$657.00	Heater & Ac Unit for Well 4 & 5	601-49440-221	PL LK/Lake Repair/operating Ex
020501	03/19/21	VISA	\$39.66	Water Samples	601-49440-322	Postage
020502	03/24/21	AMERICAN SOLUTIONS FOR BUSINES	\$15.79	Laser Checks	601-49440-200	Office Supplies
020506	03/24/21	CENTURYLINK	\$39.88	251-5836 City Hall	601-49440-321	Telephone
020506	03/24/21	CENTURYLINK	\$56.11	251-2120 Well house 3	601-49440-321	
020506	03/24/21	CENTURYLINK	\$41.28	251-1664 SCDA System	601-49440-321	
020508	03/24/21	MARCO FINANCING, INC (LEASE)	\$65.00	COPIER/LEASE	601-49440-413	Copier/Printer Lease
020514	03/24/21	THEIN WELL	\$232.50	Annual Inspection on Pumps & Wellls on 03.12.21	601-49440-220	Repair/Operating Expense
020514	03/24/21	THEIN WELL	\$232.50	Annual Inspection on Pumps & Wellls on 03.12.21	601-49440-221	PL LK/Lake Repair/operating Ex
020516	03/24/21	USA BLUEBOOK	\$196.92	Water Sampling - Hach, colorimeter tubes, flouride reagen	601-49440-220	Repair/Operating Expense
020516	03/24/21	USA BLUEBOOK	\$196.92	Water Sampling - Hach, colorimeter tubes, flouride reagen	601-49440-221	PL LK/Lake Repair/operating Ex
020519	03/31/21	HAWKINS WTR TREATMENT GRP INC	\$10.00	Chlorine Cylinder	601-49440-216	Chemicals/Chem Products
020519	03/31/21	HAWKINS WTR TREATMENT GRP INC	\$10.00	Chlorine Cylinder	601-49440-217	PL LK Chemicals/Chem Products
020520	03/31/21	LYNN PLUMSKI	\$9.37	CITY HALL	601-49440-106	Cleaning Person
020524	03/31/21	XCEL ENERGY	\$39.52	229 BROADWAY	601-49440-381	Electric Utilities
020524	03/31/21	XCEL ENERGY	\$372.20	423 MAPLE ST & 560 CHESTNUT	601-49440-381	
020524	03/31/21	XCEL ENERGY	\$74.20	209 BRDWY & 562 CHESTNUT	601-49440-381	
DEPT 49440 Water-Administration			\$5,678.41			
FUND 601 WATER FUND			\$6,377.41			
FUND 602 SEWER FUND						
DEPT 49490 Sewer-Administration						
001569	03/10/21	PAYMENT SERVICE NETWORK	\$1.24	Monthly Credit Card fee	602-49490-210	Operating Expenses
020469	03/03/21	BOLTON & MENK INC	\$900.00	Stickney Dairy (Reimb)	602-49490-303	Engineering Fees
020470	03/03/21	DELTA ELECTRIC	\$215.00	Relay	602-49490-289	Grinderstation Repairs/Parts
020470	03/03/21	DELTA ELECTRIC	\$1,818.25	Grinderstation calls Lake Area	602-49490-296	Lk Sewer Contr Srvc

CITY OF ROCKVILLE
Exp Detail Council MMB jn

Check Nbr	Check/Receipt Date	Search Name	Amount	Comments	Act Code	OBJ Descr
020471	03/03/21	GOPHER STATE ONE-CALL	\$3.38	LOCATE TICKETS-SWR DEPT	602-49490-291	Locates
020474	03/03/21	KIESS BROS	\$20.12	Fuel Sewer	602-49490-212	Gas & Oil
020475	03/03/21	LYNN PLUMSKI	\$9.37	CITY HALL	602-49490-106	Cleaning Person
020481	03/03/21	XCEL ENERGY	\$110.33	209 BRDWY & 562 CHESTNUT	602-49490-381	Electric Utilities
020481	03/03/21	XCEL ENERGY	\$322.26	398 BROADWAY ST	602-49490-381	
020481	03/03/21	XCEL ENERGY	\$51.22	229 BROADWAY	602-49490-381	
020483	03/12/21	ARAMARK	\$9.00	RENTAL OF RUGS/MOPS-CITY HALL	602-49490-209	Cleaning Supplies
020487	03/12/21	COLD SPRING RECORD INC	\$29.51	envelopes, Fees and Charge	602-49490-340	Advertising/Printing/Publishin
020490	03/12/21	INTEGRATED PROCESS SOLUTIONS	\$407.50	Grand Lake Lift station (Intrinsic Relay Install)	602-49490-221	PL LK/Lake Repair/operating Ex
020491	03/12/21	LYNN PLUMSKI	\$9.37	CITY HALL	602-49490-106	Cleaning Person
020492	03/12/21	MIDCO	\$9.44	CITY HALL	602-49490-323	Internet/E-mail/Web Site
020493	03/12/21	STEARNS ELECTRIC ASOC INC	\$81.00	10440600 Pleasant Lk Lift Stat	602-49490-381	Electric Utilities
020493	03/12/21	STEARNS ELECTRIC ASOC INC	\$35.00	12505300 1340 Prairie Dr Flume Meter	602-49490-381	
020493	03/12/21	STEARNS ELECTRIC ASOC INC	\$272.00	10406000 Prairie Dr Lift Stati	602-49490-381	
020493	03/12/21	STEARNS ELECTRIC ASOC INC	\$166.00	10405900 Co Rd 6 Lift Station	602-49490-381	
020493	03/12/21	STEARNS ELECTRIC ASOC INC	\$95.00	10405800 Co Rd 8 Lift Station	602-49490-381	
020496	03/19/21	AT & T MOBILITY	\$25.00	WIRELESS PHONE	602-49490-321	Telephone
020496	03/19/21	AT & T MOBILITY	\$30.68	GRINDERSTATION PHONE	602-49490-321	
020497	03/19/21	CENTER POINT ENERGY-MINNEGASCO	\$35.19	6394888-9 UTIL-229 CITY HALL	602-49490-383	Gas Utilities
020497	03/19/21	CENTER POINT ENERGY-MINNEGASCO	\$182.61	6109272-2 209 BRDWY-PUB WKS	602-49490-383	
020500	03/19/21	STEARNS CO AUDITOR-TREASURER	\$24.00	2021 Special Assessment	602-49490-310	Other Professional Services
020501	03/19/21	VISA	\$11.13	paper, pads, cups, can liners	602-49490-200	Office Supplies
020501	03/19/21	VISA	\$4.28	Gloves	602-49490-209	Cleaning Supplies
020501	03/19/21	VISA	\$50.20	Stickney SIC Permit (Sue, Justin, Marty, Jerry & Bill)	602-49490-331	Hotel,Meal,Prkg & Mileage Reim
020502	03/24/21	AMERICAN SOLUTIONS FOR BUSINES	\$15.79	Laser Checks	602-49490-200	Office Supplies
020503	03/24/21	BATTERIES PLUS	\$12.95	Battery for Dialer @ Main Lift station	602-49490-220	Repair/Operating Expense
020506	03/24/21	CENTURYLINK	\$41.28	251-1664 SCDA System	602-49490-321	Telephone
020506	03/24/21	CENTURYLINK	\$205.50	612-E16-2655 Sewer	602-49490-321	
020506	03/24/21	CENTURYLINK	\$69.65	685-4204 Sewer	602-49490-321	
020506	03/24/21	CENTURYLINK	\$59.55	259-1473 Sewer	602-49490-321	
020506	03/24/21	CENTURYLINK	\$39.88	251-5836 City Hall	602-49490-321	
020508	03/24/21	MARCO FINANCING, INC (LEASE)	\$75.00	COPIER/LEASE	602-49490-413	Copier/Printer Lease
020509	03/24/21	MENARDS	\$109.00	Cast Iron sump pump Main Liftstation	602-49490-220	Repair/Operating Expense
020510	03/24/21	NELSON ELECTRIC MOTOR REP INC	\$795.00	Main Liftstation-scraped grease off the walls pulled pump	602-49490-220	
020510	03/24/21	NELSON ELECTRIC MOTOR REP INC	\$450.00	Main Liftstation- Pulled Pump # 2 checked the controls	602-49490-220	
020510	03/24/21	NELSON ELECTRIC MOTOR REP INC	\$1,375.00	Voigts Liftstation - removed soft starts & installed new mo	602-49490-288	Lk Sewer Lift Station
020520	03/31/21	LYNN PLUMSKI	\$9.37	CITY HALL	602-49490-106	Cleaning Person
020521	03/31/21	NELSON ELECTRIC MOTOR REP INC	\$2,393.50	Main Lift Station install pump 2 after rebuilding, repair vol	602-49490-220	Repair/Operating Expense
020524	03/31/21	XCEL ENERGY	\$510.50	398 BROADWAY ST	602-49490-381	Electric Utilities

CITY OF ROCKVILLE
Exp Detail Council MMB jn

Check Nbr	Check/Receipt Date	Search Name	Amount	Comments	Act Code	OBJ Descr
020524	03/31/21	XCEL ENERGY	\$39.52	229 BROADWAY	602-49490-381	Electric Utilities
020524	03/31/21	XCEL ENERGY	\$74.20	209 BRDWY & 562 CHESTNUT	602-49490-381	
DEPT 49490 Sewer-Administration			<u>\$11,203.77</u>			
FUND 602 SEWER FUND			<u>\$11,203.77</u>			
			<u>\$74,815.88</u>			

ROCKVILLE CITY COUNCIL MEETING MINUTES
March 10, 2021
Rockville City Hall

Item 1) Call to Order

Item 2) Workshop Agenda

Workshop Agenda

- a) New Public Works Building – City Engineer and Architect are analyzing the bids the City received and will provide their analysis at the March 31, 2021 Council meeting.
 - Council discussed the idea of moving the regular last Monday of the month Council meeting to the last Wednesday of the month.
 - Meeting to discuss fence with residents of Caroline Lane/soccer field. Becker and Herberg will facilitate.
 - Discuss Resolution 2021-20 Authorizing City Engineer Prepare Plans and Specs for 2021 Streets discussion.
- b) Council/Public Interaction
- c) 5:45 p.m. Public Comment

Reconvene Council Meeting at 6:00 p.m.

Item 3) Pledge of Allegiance

Item 4) Roll Call

Roll call was taken and the following members were present: Acting Mayor Brian Herberg, Bill Becker, Brian Stanger, and Jerry Tippelt. Absent: Duane Willenbring.

Staff members present: City Administrator, Martin Bode; City Attorney, Susan Dege; City Engineer, Justin Kannas; and Public Works Director, Gene Van Havermaet.

Others present: Janelle P. Kendall, Stearns County Attorney, and Don Simon.

Item 5) Additions/Approval of Agenda

Additions; 11a) Date change for the Last Monday of the Month meeting and 11b) Resolution 2021-20 Prepare Plans and Specifications for 2021/2022 Street Improvements.

Motion by Becker, second by Tippelt, to approve the agenda with the additions as noted. Motion passed unanimously.

Item 6) Resolution 2021-19 Acceptance of February 2021 Donations

Motion by Becker, second by Stanger, to approve Resolution 2021-19 Acceptance of February 2021 Donations. Motion passed unanimously.

Item 7) Approval of February 2021 Bills Paid

Motion by Becker, second by Tippelt, to approve the February 2021 bills paid. Motion passed unanimously.

Item 8) Consent Agenda

- a) Approval Rockville City Council Minutes of February 10 and February 22, 2021
- b) Acknowledge February 2021 Building Permits
- c) Acknowledge February Sheriff's Report

Motion by Stanger, second by Tippelt, to approve the Consent Agenda as presented. Motion passed unanimously.

Item 9) City Prosecution Review and Update - Stearns County Attorney Janelle P. Kendall

Kendall provided Council a brief overview of the 2020 Rockville Prosecution Contract Report.

Item 10) Department Reports

- a) Sheriff's Report – Council noted written report was in the packet.
- b) City Engineer, Justin Kannas

1) Harstad Development

- a. SRWD Rockville Crossing Storm Water Management Plan

Motion by Stanger, second by Tippelt, to approve the Sauk River Watershed Rockville Crossing Storm Management Plan as presented. Motion passed unanimously.

2) Loves Development Agreement

Motion by Becker, second by Tippelt, to approve the Loves Development Agreement, subject to reasonable minor staff modifications. Motion passed unanimously.

3) Street Management Plan

Council acknowledged the plan and possible options for its implementation is still under discussion.

c) Public Works, Director Gene Van Havermaet

Van Havermaet reviewed with Council his written report of recent public works activity.

Item 11) Administration

- a) Council discussed the idea of moving the regular last Monday of the month Council meeting to the last Wednesday of the month.

Motion by Becker, second by Stanger to approve changing the Last Monday of the Month Regular Council Meeting to the Last Wednesday of the Month and noted the meeting time would stay the same at 5:30 p.m. Motion passed unanimously.

- b) Resolution 2021-20 Authorizing Preparation of Plans and Specifications 2021-2022 Street Improvements

Motion by Herberg, second by Stanger, to approve Resolution 2021-20 Authorizing Preparation of Plans and Specifications 2021-2022 Street Improvements as presented. Motion passed unanimously.

Item 12) Action Items

- a) Council Action Worksheet, Appropriations, Allocations and Transfers – none to report.

Item 13) Closed Session

Per State Statute 13D.05, subd. 3(b) Attorney-Client Privilege, to discuss active and pending litigation.

Reconvene

- a) Summarize Closed Session

Attorney Dege stated that the Council during closed session discussed the lawsuit between the City of Rockville and Stickney Hill Dairy related to solid waste treatment and the related water sewer bills. Dege recommended the Council approve of the new March 10, 2021 Significant Industrial User (SIU) permit/agreement and furthermore agree to go back to mediation with Stickney.

- b) Council Action New SIU Permit dated March 10, 2021.

Motion by Becker, second by Stanger, to approve the new Stickney Hill Dairy SIU permit dated March 10, 2021. Motion passed unanimously.

- c) Mediation

Motion by Herberg, second by Stanger, to approve going back into mediation with Stickney Hill Dairy with Kimm Pennington as the mediator. Motion passed unanimously.

Item 14) Adjourn

Motion by Becker, second by Tippelt, to adjourn the meeting at 6:57 p.m. Motion carried.

Respectfully submitted,

Martin M. Bode
City Administrator

ROCKVILLE CITY COUNCIL LAST WEDNESDAY OF THE MONTH MEETING MINUTES
March 31, 2021
Rockville City Hall

Item 1) Call to Order

The meeting was called to order at 5:30 p.m. by Mayor Duane Willenbring.

Item 2) Roll Call

Roll call was taken and the following members were present: Brian Stanger, Brian Herberg, Jerry Tippelt, Bill Becker, and Duane Willenbring.

Staff members present: City Administrator, Martin Bode; Public Works Director, Gene VanHavermaet; City Engineer, Justin Kannas; Jake Wollensak, Wold Architects; John Arnzen, Jim Kuechle, and Jerry Haus.

Item 3) Additions/Approval of Agenda

Motion by Herberg, second by Stanger, to approve of the agenda as presented. Motion passed unanimously.

Item 4) New Public Works Building

- a) Bid / Quote Review – Council, staff and local contractors reviewed the bids that were received for the proposed new public works building. There was a lot of concern on how a simple heated post frame constructed building turns into a 500 plus page bid packet with bids coming in at a range from \$860,000 to \$1,084,300.

Motion by Tippelt to accept the low bid from Project One and amend the project to construct the building with a concrete floor and leave one half of the building as cold storage. Motion failed due to a lack of a second.

After considerable debate it was the consensus of the Council to schedule a workshop strictly for the purpose of reviewing the architectural design plans and remove items to bring the cost down.

- b) Accept / Reject Bid(s)

Motion by Willenbring, second by Stanger, to reject the bid(s) and return the bid bonds. Motion passed unanimously.

Item 5) Engineer Brentwood 2nd Addition Concept Plan

Administrator Bode informed the Council that he has been in talks with a developer that is extremely interested in purchasing and developing all of the Brentwood 2nd Addition. Bode stated with that in mind he would like to ask the Council to suspend/postpone any further action by the City Engineer as it relates to Resolution 2021-15 authorizing preparation of pre-final and specifications of Brentwood 2nd Addition.

Motion by Herberg, second by Becker, to approve Administrator Bode's recommendation and suspend/postpone City Engineer performing any further action of Resolution 2021-15. Motion passed unanimously.

Item 6) Eichi Development Water/Sewer Extension

Engineer Kannas reported to the Council that in light of the large amount of dewatering that will be required to extend the Eichi sewer main to the Eichi property it would be financially prudent for the Council to consider spending an additional \$200,000 to also install the water/sewer wyes every 80-85 feet (due to the high groundwater) thereby saving the cost of re-dewatering and digging up the main to do it at a later time.

Motion by Herberg, second by Tippelt, to approve the installation of the water/sewer wyes during the Eichi Sewer Extension at an estimated cost of \$200,000. Motion passed unanimously.

Item 7) Streets/Roads

- a) 260th Street shared with St. Joseph Township – Crack Fill / Seal Coat 2021 Project

Administrator Bode reported to the Council that St. Joseph Township has notified him that they would like to crack fill and seal coat 260th Street this year which is a shared road with the City of Rockville.

Motion by Herberg, second by Becker, to approve St. Joseph Township's request to crack fill and seal coat 260th Street. Motion passed unanimously.

- b) Street Development/Construction/Design Standards – No discussion.

Item 8) WWTP Grant, Programs and Capacity

Administrator Bode informed the Council he has been looking into possible grant/funding options for the City as it relates to helping Stickney Hill install a pretreatment plant for their facility and/or the City of Rockville expanding their own sewer capacity either be it through a plant expansion with the City of Cold Spring or the City of Rockville look into constructing their own treatment plant.

Item 9) Council Action

- a) Cold Spring Mower

Director VanHavermaet reviewed with the Council an option of replacing the city's current 4-foot hammer mower with a used 6-foot flail mower at a cost of \$2,400.00.

Motion by Tippelt, second by Becker, to approve the mower purchase from the City of Cold Spring. Roll call vote: Ayes; Tippelt and Becker. Nays; Herberg, Willenbring, and Stanger. Motion failed on a 2 to 3 vote.

- b) Shouldering Conveyor Box Attachment

Director VanHavermaet reviewed with the Council a Shouldering Conveyor Box attachment that would be attached to one of the city's dump trucks to help with adding shouldering mix (gravel) to the city's streets, at an estimated cost of \$4,000.00.

Motion by Becker, second by Tippelt, to approve the Shouldering Conveyor Box Attachment estimated cost of \$4,000.00. Roll call vote: Ayes; Herberg, Tippelt, and Becker. Nays; Willenbring and Stanger. Motion carried on a 3 to 2 vote.

- c) City of Cold Spring Invoice

Bode reviewed with the Council an invoice the City had received from the City of Cold Spring. The invoice was for the City of Cold Spring expense of hiring an attorney to send the City of Rockville a violation notice as it relates to Stickney Hill Dairy that has not at times had an SIU permit with the City of Rockville as required by State Statue. Bode stated he has requested additional information from the City of Cold Spring and requested the Council postpone action.

Motion by Willenbring, second by Stanger, to postpone payment to the City of Cold Spring Invoice. Roll call vote: Ayes; Tippelt, Willenbring, and Stanger. Nays; Herberg and Becker. Motion carried on a 3 to 2 vote.

Item 10) AT&T Contract Renewal Discussion

Bode noted that he is continuing to work with AT&T with the help of City Engineer and City Attorney to iron out the antenna lease renewal agreement.

Item 11) Stickney Hill Dairy

Item 12) Grand Lake LID – Cleaning Station

Bode reported that the Grand Lake LID would like to install a boat cleaning station at the DNR boat landing on Grand Lake. The requirement would need the City to lease the land from the DNR and own and insure

the equipment. The LID would reimburse the City all related costs. Consensus of the Council was this would be an acceptable arrangement.

Item 13) Other

a) AED (Automated External Defibrillator)

Council discussed that there is a Lions AED project going on where the Lions are proposing to install eight AED stations. Six in the City of Rockville and two in Maine Prairie Township. The City is being asked to pay for the installation of the AED station that would be installed in the City Hall parking lot near the Utility Drop box at an estimated cost of \$5,000.00. The City is also being asked to pay the \$2,100.00 annual maintenance fee for the 6 AED stations that are located in the City of Rockville.

Motion by Becker, second by Stanger, to approve the AED expense of \$4-5,000.00 plus yearly maintenance fees of all 6 AEDs located in the City of Rockville. Motion passed unanimously.

b) Future Agenda – Council Workshop

Item 14) Adjourn

***Motion by Becker, second by Herberg, to adjourn the meeting. Motion carried.
Meeting adjourned at 8:23 p.m.***

Respectfully submitted,

Martin M. Bode, City Administrator

CITY OF ROCKVILLE

04/08/21 3:38 PM

Journal Entries

Page 1

Current Period: JANUARY 2021

Batch Name 010421JE

Refer		Debit	Credit
46	Prepaid Annual Shadow Protect License		
	G 101-13000 Prepaid Expense	\$0.00	\$964.44
	E 101-41110-309 Computer Svcs, Software & Sply	\$137.78	\$0.00
	E 101-42200-309 Computer Svcs, Software & Sply	\$137.78	\$0.00
	E 101-42500-309 Computer Svcs, Software & Sply	\$137.78	\$0.00
	E 101-46300-309 Computer Svcs, Software & Sply	\$137.78	\$0.00
	E 101-43100-309 Computer Svcs, Software & Sply	\$137.77	\$0.00
	E 101-41800-309 Computer Svcs, Software & Sply	\$137.77	\$0.00
	E 101-41000-309 Computer Svcs, Software & Sply	\$137.78	\$0.00
	E 602-49490-309 Computer Svcs, Software & Sply	\$137.78	\$0.00
	E 601-49440-309 Computer Svcs, Software & Sply	\$137.78	\$0.00
	G 601-13000 Prepaid Expense	\$0.00	\$137.78
	G 602-13000 Prepaid Expense	\$0.00	\$137.78
Transaction Date	1/4/2021	Total	\$1,240.00
47	Prepaid WCI Prem 01/01-06/30/21		
	G 101-13000 Prepaid Expense	\$0.00	\$7,876.00
	G 601-13000 Prepaid Expense	\$0.00	\$452.50
	G 602-13000 Prepaid Expense	\$0.00	\$567.00
	E 601-49440-151 Worker s Comp Insurance Prem	\$452.50	\$0.00
	E 602-49490-151 Worker s Comp Insurance Prem	\$567.00	\$0.00
	E 101-42200-151 Worker s Comp Insurance Prem	\$3,340.50	\$0.00
	E 101-41800-151 Worker s Comp Insurance Prem	\$623.00	\$0.00
	E 101-45122-151 Worker s Comp Insurance Prem	\$577.00	\$0.00
	E 101-41110-151 Worker s Comp Insurance Prem	\$20.25	\$0.00
	E 101-46300-151 Worker s Comp Insurance Prem	\$20.25	\$0.00
	E 101-43100-151 Worker s Comp Insurance Prem	\$3,295.00	\$0.00
Transaction Date	1/4/2021	Total	\$8,895.50
52	Prepaid Liability Insurance 01/01/21-06/30/21		
	G 101-13000 Prepaid Expense	\$0.00	\$11,974.71
	G 601-13000 Prepaid Expense	\$0.00	\$1,131.20
	G 602-13000 Prepaid Expense	\$0.00	\$1,786.59
	E 602-49490-361 General Liability Ins	\$1,786.59	\$0.00
	E 601-49440-361 General Liability Ins	\$1,131.20	\$0.00
	E 101-46300-361 General Liability Ins	\$1,571.00	\$0.00
	E 101-45122-361 General Liability Ins	\$3,123.51	\$0.00
	E 101-43100-361 General Liability Ins	\$3,497.90	\$0.00
	E 101-42800-361 General Liability Ins	\$40.00	\$0.00
	E 101-42500-361 General Liability Ins	\$30.00	\$0.00
	E 101-42200-361 General Liability Ins	\$2,628.02	\$0.00
	E 101-41800-361 General Liability Ins	\$124.70	\$0.00
	E 101-41410-361 General Liability Ins	\$8.00	\$0.00
	E 101-41110-361 General Liability Ins	\$102.10	\$0.00
	E 101-41000-361 General Liability Ins	\$849.48	\$0.00
Transaction Date	1/4/2021	Total	\$14,892.50
53	Fire Contract 2020-2021 01.01-03.21.21		
	G 101-22100 Undistributed Receipts	\$6,433.00	\$0.00
	R 101-42200-34202 Fire Contract Revenue	\$0.00	\$6,433.00
Transaction Date	1/4/2021	Total	\$6,433.00

CITY OF ROCKVILLE
Journal Entries

04/08/21 3:38 PM
Page 2

Current Period: JANUARY 2021

Fund Summary

		Debit	Credit	Difference
Refer 46	101 GENERAL FUND	\$964.44	\$964.44	In Balance
	601 WATER FUND	\$137.78	\$137.78	In Balance
	602 SEWER FUND	\$137.78	\$137.78	In Balance
Refer 47	101 GENERAL FUND	\$7,876.00	\$7,876.00	In Balance
	601 WATER FUND	\$452.50	\$452.50	In Balance
	602 SEWER FUND	\$567.00	\$567.00	In Balance
Refer 52	101 GENERAL FUND	\$11,974.71	\$11,974.71	In Balance
	601 WATER FUND	\$1,131.20	\$1,131.20	In Balance
	602 SEWER FUND	\$1,786.59	\$1,786.59	In Balance
Refer 53	101 GENERAL FUND	\$6,433.00	\$6,433.00	In Balance

For each fund the Debits MUST equal Credits to be In Balance.

Batch Name 010521JE

Refer	55 Annual Website Hosting Storage Plan	Debit	Credit
	G 601-13000 Prepaid Expense	\$0.00	\$110.00
	G 602-13000 Prepaid Expense	\$0.00	\$110.00
	G 101-13000 Prepaid Expense	\$0.00	\$770.00
	E 101-42500-323 Internet/E-mail/Web Site	\$110.00	\$0.00
	E 101-42200-323 Internet/E-mail/Web Site	\$110.00	\$0.00
	E 602-49490-323 Internet/E-mail/Web Site	\$110.00	\$0.00
	E 601-49440-323 Internet/E-mail/Web Site	\$110.00	\$0.00
	E 101-46300-323 Internet/E-mail/Web Site	\$110.00	\$0.00
	E 101-43100-323 Internet/E-mail/Web Site	\$110.00	\$0.00
	E 101-41800-323 Internet/E-mail/Web Site	\$110.00	\$0.00
	E 101-41110-323 Internet/E-mail/Web Site	\$110.00	\$0.00
	E 101-41000-323 Internet/E-mail/Web Site	\$110.00	\$0.00
Transaction Date	1/4/2021	Total	\$990.00
		\$990.00	\$990.00

Fund Summary

		Debit	Credit	Difference
Refer 55	101 GENERAL FUND	\$770.00	\$770.00	In Balance
	601 WATER FUND	\$110.00	\$110.00	In Balance
	602 SEWER FUND	\$110.00	\$110.00	In Balance

For each fund the Debits MUST equal Credits to be In Balance.

Batch Name 011321JE

Refer	-1 Labor Distribution	Debit	Credit
	E 101-42800-101 City Administrator	\$5.26	\$0.00
	E 101-42200-108 Administrative Assistant	\$17.76	\$0.00
	E 101-42200-109 Public Works Maintenance	\$11.01	\$0.00
	E 101-42200-121 PERA	\$8.64	\$0.00
	E 101-42200-122 FICA-Social Security	\$7.12	\$0.00
	E 101-42200-123 Medicare	\$1.67	\$0.00
	E 101-42200-131 Health Insurance	\$18.64	\$0.00
	E 101-42500-101 City Administrator	\$26.30	\$0.00
	E 101-42500-105 Finance/Billing Clerk/Admin	\$5.01	\$0.00
	E 101-42500-108 Administrative Assistant	\$22.19	\$0.00
	E 101-42500-121 PERA	\$4.01	\$0.00
	E 101-42500-122 FICA-Social Security	\$3.36	\$0.00
	E 101-41000-101 City Administrator	\$163.08	\$0.00

CITY OF ROCKVILLE

Journal Entries

Current Period: JANUARY 2021

E 101-42500-131 Health Insurance	\$3.14	\$0.00
E 101-42200-101 City Administrator	\$31.56	\$0.00
E 101-42800-102 Public Works Director	\$4.93	\$0.00
E 101-42800-105 Finance/Billing Clerk/Admin	\$5.01	\$0.00
E 101-42800-109 Public Works Maintenance	\$3.67	\$0.00
E 101-42800-121 PERA	\$1.41	\$0.00
E 101-42800-122 FICA-Social Security	\$1.19	\$0.00
E 101-42800-123 Medicare	\$0.28	\$0.00
E 101-42800-131 Health Insurance	\$2.56	\$0.00
E 101-43100-101 City Administrator	\$105.21	\$0.00
E 101-43100-102 Public Works Director	\$1,035.15	\$0.00
E 101-43100-104 Seasonal/Temp/Committee	\$118.93	\$0.00
E 101-43100-105 Finance/Billing Clerk/Admin	\$205.18	\$0.00
E 101-43100-108 Administrative Assistant	\$8.88	\$0.00
E 101-42500-123 Medicare	\$0.79	\$0.00
E 101-41110-131 Health Insurance	\$32.92	\$0.00
E 101-41000-102 Public Works Director	\$19.71	\$0.00
E 101-41000-105 Finance/Billing Clerk/Admin	\$75.06	\$0.00
E 101-41000-108 Administrative Assistant	\$117.64	\$0.00
E 101-41000-109 Public Works Maintenance	\$7.34	\$0.00
E 101-41000-121 PERA	\$28.71	\$0.00
E 101-41000-122 FICA-Social Security	\$24.00	\$0.00
E 101-41000-123 Medicare	\$5.62	\$0.00
E 101-41000-131 Health Insurance	\$39.82	\$0.00
E 101-41110-101 City Administrator	\$604.96	\$0.00
E 101-41110-105 Finance/Billing Clerk/Admin	\$20.01	\$0.00
E 101-41110-108 Administrative Assistant	\$35.51	\$0.00
E 101-41110-121 PERA	\$49.54	\$0.00
E 101-42200-105 Finance/Billing Clerk/Admin	\$40.04	\$0.00
E 101-41110-123 Medicare	\$9.90	\$0.00
E 101-42200-102 Public Works Director	\$14.79	\$0.00
E 101-41410-101 City Administrator	\$26.30	\$0.00
E 101-41410-121 PERA	\$1.97	\$0.00
E 101-41410-122 FICA-Social Security	\$1.63	\$0.00
E 101-41410-123 Medicare	\$0.38	\$0.00
E 101-41800-101 City Administrator	\$136.77	\$0.00
E 101-41800-105 Finance/Billing Clerk/Admin	\$478.41	\$0.00
E 101-41800-108 Administrative Assistant	\$208.64	\$0.00
E 101-41800-121 PERA	\$61.79	\$0.00
E 101-41800-122 FICA-Social Security	\$49.78	\$0.00
E 101-41800-123 Medicare	\$11.64	\$0.00
E 101-41800-131 Health Insurance	\$203.36	\$0.00
E 101-43100-122 FICA-Social Security	\$141.34	\$0.00
E 101-41110-122 FICA-Social Security	\$42.35	\$0.00
E 602-49490-123 Medicare	\$18.56	\$0.00
E 101-43100-109 Public Works Maintenance	\$763.66	\$0.00
E 601-49440-108 Administrative Assistant	\$88.79	\$0.00
E 601-49440-109 Public Works Maintenance	\$220.29	\$0.00
E 601-49440-121 PERA	\$82.34	\$0.00
E 601-49440-122 FICA-Social Security	\$67.58	\$0.00
E 601-49440-123 Medicare	\$15.80	\$0.00
E 601-49440-131 Health Insurance	\$200.29	\$0.00
E 602-49490-101 City Administrator	\$52.61	\$0.00
E 602-49490-102 Public Works Director	\$335.19	\$0.00

CITY OF ROCKVILLE

04/08/21 3:38 PM

Journal Entries

Page 4

Current Period: JANUARY 2021

E 602-49490-105 Finance/Billing Clerk/Admin	\$520.44	\$0.00
E 602-49490-108 Administrative Assistant	\$133.18	\$0.00
E 602-49490-109 Public Works Maintenance	\$249.66	\$0.00
E 601-49440-102 Public Works Director	\$295.76	\$0.00
E 602-49490-122 FICA-Social Security	\$79.41	\$0.00
E 601-49440-101 City Administrator	\$52.61	\$0.00
E 602-49490-131 Health Insurance	\$235.52	\$0.00
E 602-49490-331 Hotel,Meal,Prkg & Mileage Reim	\$16.21	\$0.00
G 101-10600 Cash	\$0.00	\$4,412.25
G 101-21701 Federal Withholding	\$0.00	\$1,504.54
G 101-21702 State Withholding	\$0.00	\$651.38
G 101-21703 FICA/Medicare Withholding	\$0.00	\$1,963.50
G 101-21704 PERA	\$0.00	\$1,756.19
G 101-21705 Health Insurance	\$0.00	\$144.83
G 101-21706 City Portion Health Ins	\$0.00	\$1,158.63
G 101-21709 Short/Long-Term Disability	\$0.00	\$32.48
G 221-10600 Cash	\$0.00	\$8.77
G 601-10600 Cash	\$0.00	\$2,049.34
E 602-49490-121 PERA	\$96.84	\$0.00
E 101-46300-105 Finance/Billing Clerk/Admin	\$200.17	\$0.00
G 602-10600 Cash	\$0.00	\$2,432.67
E 101-43100-123 Medicare	\$33.06	\$0.00
E 101-43100-131 Health Insurance	\$145.36	\$0.00
E 101-45122-101 City Administrator	\$65.76	\$0.00
E 101-45122-102 Public Works Director	\$261.25	\$0.00
E 101-45122-105 Finance/Billing Clerk/Admin	\$10.01	\$0.00
E 101-45122-108 Administrative Assistant	\$6.66	\$0.00
E 101-45122-109 Public Works Maintenance	\$209.27	\$0.00
E 101-45122-121 PERA	\$41.46	\$0.00
E 101-45122-122 FICA-Social Security	\$35.19	\$0.00
E 101-45122-123 Medicare	\$8.23	\$0.00
E 101-45122-131 Health Insurance	\$21.01	\$0.00
E 601-49440-105 Finance/Billing Clerk/Admin	\$440.38	\$0.00
E 101-46300-102 Public Works Director	\$4.93	\$0.00
E 101-43100-121 PERA	\$158.84	\$0.00
E 101-46300-108 Administrative Assistant	\$248.60	\$0.00
E 101-46300-109 Public Works Maintenance	\$3.67	\$0.00
E 101-46300-121 PERA	\$136.11	\$0.00
E 101-46300-122 FICA-Social Security	\$115.12	\$0.00
E 101-46300-123 Medicare	\$26.93	\$0.00
E 101-46300-131 Health Insurance	\$138.31	\$0.00
E 221-41000-101 City Administrator	\$2.63	\$0.00
E 221-41000-105 Finance/Billing Clerk/Admin	\$2.00	\$0.00
E 221-41000-121 PERA	\$0.35	\$0.00
E 221-41000-122 FICA-Social Security	\$0.27	\$0.00
E 221-41000-123 Medicare	\$0.07	\$0.00
E 221-41000-131 Health Insurance	\$0.94	\$0.00
E 101-46300-101 City Administrator	\$1,357.23	\$0.00
G 101-20400 Salaries Payable	\$3,321.10	\$0.00
G 221-20400 Salaries Payable	\$2.51	\$0.00
G 601-20400 Salaries Payable	\$585.50	\$0.00
G 602-20400 Salaries Payable	\$695.05	\$0.00
Transaction Date 1/14/2021	Total	
	\$16,114.58	\$16,114.58

CITY OF ROCKVILLE
Journal Entries

Current Period: JANUARY 2021

Fund Summary

		Debit	Credit	Difference
Refer -1	101 GENERAL FUND	\$11,623.80	\$11,623.80	In Balance
	221 LAKE IMPROVEMENT DISTRIC	\$8.77	\$8.77	In Balance
	601 WATER FUND	\$2,049.34	\$2,049.34	In Balance
	602 SEWER FUND	\$2,432.67	\$2,432.67	In Balance

For each fund the Debits MUST equal Credits to be In Balance.

Batch Name 012621JE

Refer	-1 Labor Distribution	Debit	Credit
E 101-42800-101	City Administrator	\$7.36	\$0.00
E 101-42200-108	Administrative Assistant	\$24.86	\$0.00
E 101-42200-109	Public Works Maintenance	\$15.52	\$0.00
E 101-42200-121	PERA	\$12.13	\$0.00
E 101-42200-122	FICA-Social Security	\$10.00	\$0.00
E 101-42200-123	Medicare	\$2.34	\$0.00
E 101-42200-131	Health Insurance	\$2.93	\$0.00
E 101-42500-101	City Administrator	\$36.82	\$0.00
E 101-42500-105	Finance/Billing Clerk/Admin	\$7.01	\$0.00
E 101-42500-108	Administrative Assistant	\$31.07	\$0.00
E 101-42500-121	PERA	\$5.62	\$0.00
E 101-42500-122	FICA-Social Security	\$4.71	\$0.00
E 101-43100-109	Public Works Maintenance	\$1,075.80	\$0.00
E 101-42500-131	Health Insurance	\$1.50	\$0.00
E 101-42200-101	City Administrator	\$44.19	\$0.00
E 101-42800-102	Public Works Director	\$7.01	\$0.00
E 101-42800-105	Finance/Billing Clerk/Admin	\$7.01	\$0.00
E 101-42800-109	Public Works Maintenance	\$5.17	\$0.00
E 101-42800-121	PERA	\$2.00	\$0.00
E 101-42800-122	FICA-Social Security	\$1.66	\$0.00
E 101-42800-123	Medicare	\$0.39	\$0.00
E 101-42800-131	Health Insurance	\$0.68	\$0.00
E 101-43100-101	City Administrator	\$147.30	\$0.00
E 101-43100-102	Public Works Director	\$1,471.26	\$0.00
E 101-43100-104	Seasonal/Temp/Committee	\$846.00	\$0.00
E 101-43100-105	Finance/Billing Clerk/Admin	\$287.25	\$0.00
E 101-41000-101	City Administrator	\$228.31	\$0.00
E 101-42500-123	Medicare	\$1.10	\$0.00
E 101-41110-131	Health Insurance	\$34.50	\$0.00
E 101-41000-102	Public Works Director	\$28.02	\$0.00
E 101-41000-105	Finance/Billing Clerk/Admin	\$105.09	\$0.00
E 101-41000-108	Administrative Assistant	\$164.70	\$0.00
E 101-41000-109	Public Works Maintenance	\$10.34	\$0.00
E 101-41000-121	PERA	\$40.22	\$0.00
E 101-41000-122	FICA-Social Security	\$33.63	\$0.00
E 101-41000-123	Medicare	\$7.87	\$0.00
E 101-41000-131	Health Insurance	\$12.30	\$0.00
E 101-41110-101	City Administrator	\$846.95	\$0.00
E 101-41110-105	Finance/Billing Clerk/Admin	\$28.02	\$0.00
E 101-41110-108	Administrative Assistant	\$49.72	\$0.00
E 101-41110-121	PERA	\$69.35	\$0.00
E 101-42200-105	Finance/Billing Clerk/Admin	\$56.05	\$0.00
E 101-41110-123	Medicare	\$13.86	\$0.00

CITY OF ROCKVILLE

04/08/21 3:38 PM

Journal Entries

Page 6

Current Period: JANUARY 2021

E 101-42200-102 Public Works Director	\$21.02	\$0.00
E 101-41410-101 City Administrator	\$36.82	\$0.00
E 101-41410-121 PERA	\$2.76	\$0.00
E 101-41410-122 FICA-Social Security	\$2.28	\$0.00
E 101-41410-123 Medicare	\$0.53	\$0.00
E 101-41800-101 City Administrator	\$191.48	\$0.00
E 101-41800-105 Finance/Billing Clerk/Admin	\$669.77	\$0.00
E 101-41800-108 Administrative Assistant	\$292.10	\$0.00
E 101-41800-121 PERA	\$86.51	\$0.00
E 101-41800-122 FICA-Social Security	\$69.69	\$0.00
E 101-41800-123 Medicare	\$16.29	\$0.00
E 101-41800-131 Health Insurance	\$7.80	\$0.00
E 101-43100-121 PERA	\$224.54	\$0.00
E 101-41110-122 FICA-Social Security	\$59.29	\$0.00
E 602-49490-122 FICA-Social Security	\$111.75	\$0.00
E 601-49440-105 Finance/Billing Clerk/Admin	\$616.53	\$0.00
E 601-49440-108 Administrative Assistant	\$124.30	\$0.00
E 601-49440-109 Public Works Maintenance	\$310.33	\$0.00
E 601-49440-121 PERA	\$115.88	\$0.00
E 601-49440-122 FICA-Social Security	\$95.12	\$0.00
E 601-49440-123 Medicare	\$22.24	\$0.00
E 601-49440-131 Health Insurance	\$25.50	\$0.00
E 602-49490-101 City Administrator	\$73.65	\$0.00
E 602-49490-102 Public Works Director	\$476.41	\$0.00
E 602-49490-105 Finance/Billing Clerk/Admin	\$728.62	\$0.00
E 602-49490-108 Administrative Assistant	\$186.45	\$0.00
E 101-43100-108 Administrative Assistant	\$12.43	\$0.00
E 602-49490-121 PERA	\$136.27	\$0.00
E 221-41000-131 Health Insurance	\$0.16	\$0.00
E 602-49490-123 Medicare	\$26.13	\$0.00
E 602-49490-131 Health Insurance	\$28.47	\$0.00
E 602-49490-331 Hotel,Meal,Prkg & Mileage Reim	\$11.20	\$0.00
G 101-10600 Cash	\$0.00	\$5,498.48
G 101-21701 Federal Withholding	\$0.00	\$1,590.19
G 101-21702 State Withholding	\$0.00	\$691.21
G 101-21703 FICA/Medicare Withholding	\$0.00	\$2,075.86
G 101-21704 PERA	\$0.00	\$1,763.88
G 101-21705 Health Insurance	\$0.00	\$144.83
G 101-21709 Short/Long-Term Disability	\$0.00	\$32.48
G 221-10600 Cash	\$0.00	\$7.61
G 601-10600 Cash	\$0.00	\$1,803.91
E 602-49490-109 Public Works Maintenance	\$351.70	\$0.00
E 101-46300-105 Finance/Billing Clerk/Admin	\$280.24	\$0.00
E 101-43100-122 FICA-Social Security	\$241.78	\$0.00
E 101-43100-123 Medicare	\$56.56	\$0.00
E 101-43100-131 Health Insurance	\$84.75	\$0.00
E 101-45122-101 City Administrator	\$92.06	\$0.00
E 101-45122-102 Public Works Director	\$371.32	\$0.00
E 101-45122-105 Finance/Billing Clerk/Admin	\$14.01	\$0.00
E 101-45122-108 Administrative Assistant	\$9.32	\$0.00
E 101-45122-109 Public Works Maintenance	\$294.81	\$0.00
E 101-45122-121 PERA	\$58.61	\$0.00
E 101-45122-122 FICA-Social Security	\$49.72	\$0.00
E 101-45122-123 Medicare	\$11.63	\$0.00

CITY OF ROCKVILLE

Journal Entries

Current Period: JANUARY 2021

E 101-45122-131 Health Insurance	\$23.63	\$0.00
E 601-49440-102 Public Works Director	\$420.36	\$0.00
E 101-46300-102 Public Works Director	\$7.01	\$0.00
E 601-49440-101 City Administrator	\$73.65	\$0.00
E 101-46300-108 Administrative Assistant	\$348.04	\$0.00
E 101-46300-109 Public Works Maintenance	\$5.18	\$0.00
E 101-46300-121 PERA	\$190.55	\$0.00
E 101-46300-122 FICA-Social Security	\$161.18	\$0.00
E 101-46300-123 Medicare	\$37.70	\$0.00
E 101-46300-131 Health Insurance	\$77.78	\$0.00
E 221-41000-101 City Administrator	\$3.68	\$0.00
E 221-41000-105 Finance/Billing Clerk/Admin	\$2.80	\$0.00
E 221-41000-121 PERA	\$0.49	\$0.00
E 221-41000-122 FICA-Social Security	\$0.38	\$0.00
E 221-41000-123 Medicare	\$0.10	\$0.00
G 602-10600 Cash	\$0.00	\$2,130.65
E 101-46300-101 City Administrator	\$1,900.12	\$0.00
Transaction Date 1/28/2021	Total	\$15,739.10
		\$15,739.10

Fund Summary

	Debit	Credit	Difference
Refer -1 101 GENERAL FUND	\$11,796.93	\$11,796.93	In Balance
221 LAKE IMPROVEMENT DISTRIC	\$7.61	\$7.61	In Balance
601 WATER FUND	\$1,803.91	\$1,803.91	In Balance
602 SEWER FUND	\$2,130.65	\$2,130.65	In Balance

For each fund the Debits MUST equal Credits to be In Balance.

Batch Name 020921JE

Refer		Debit	Credit
-1	Labor Distribution		
E 101-42800-102	Public Works Director	\$7.01	\$0.00
E 101-43100-121	PERA	\$224.03	\$0.00
E 101-42200-109	Public Works Maintenance	\$15.42	\$0.00
E 101-42200-121	PERA	\$12.11	\$0.00
E 101-42200-122	FICA-Social Security	\$9.99	\$0.00
E 101-42200-123	Medicare	\$2.34	\$0.00
E 101-42200-131	Health Insurance	\$26.10	\$0.00
E 101-42500-101	City Administrator	\$36.82	\$0.00
E 101-42500-105	Finance/Billing Clerk/Admin	\$7.01	\$0.00
E 101-42500-108	Administrative Assistant	\$31.07	\$0.00
E 101-42500-121	PERA	\$5.62	\$0.00
E 101-42500-122	FICA-Social Security	\$4.71	\$0.00
E 101-42500-123	Medicare	\$1.10	\$0.00
E 101-42200-105	Finance/Billing Clerk/Admin	\$56.05	\$0.00
E 101-42800-101	City Administrator	\$7.36	\$0.00
E 101-42200-102	Public Works Director	\$21.02	\$0.00
E 101-42800-105	Finance/Billing Clerk/Admin	\$7.01	\$0.00
E 101-42800-109	Public Works Maintenance	\$5.14	\$0.00
E 101-42800-121	PERA	\$1.99	\$0.00
E 101-42800-122	FICA-Social Security	\$1.66	\$0.00
E 101-42800-123	Medicare	\$0.39	\$0.00
E 101-42800-131	Health Insurance	\$3.58	\$0.00
E 101-43100-101	City Administrator	\$147.30	\$0.00
E 101-43100-102	Public Works Director	\$1,471.26	\$0.00

CITY OF ROCKVILLE

04/08/21 3:38 PM

Journal Entries

Page 8

Current Period: FEBRUARY 2021

E 101-43100-104 Seasonal/Temp/Committee	\$288.00	\$0.00
E 101-43100-105 Finance/Billing Clerk/Admin	\$287.25	\$0.00
E 101-43100-108 Administrative Assistant	\$12.43	\$0.00
E 101-41000-101 City Administrator	\$228.31	\$0.00
E 101-42500-131 Health Insurance	\$4.40	\$0.00
E 101-41110-131 Health Insurance	\$46.09	\$0.00
E 101-41000-102 Public Works Director	\$28.02	\$0.00
E 101-41000-105 Finance/Billing Clerk/Admin	\$105.09	\$0.00
E 101-41000-108 Administrative Assistant	\$164.70	\$0.00
E 101-41000-109 Public Works Maintenance	\$10.28	\$0.00
E 101-41000-121 PERA	\$40.22	\$0.00
E 101-41000-122 FICA-Social Security	\$33.63	\$0.00
E 101-41000-123 Medicare	\$7.87	\$0.00
E 101-41000-131 Health Insurance	\$55.75	\$0.00
E 101-41110-101 City Administrator	\$846.95	\$0.00
E 101-41110-105 Finance/Billing Clerk/Admin	\$28.02	\$0.00
E 101-41110-108 Administrative Assistant	\$49.72	\$0.00
E 101-41110-121 PERA	\$69.35	\$0.00
E 101-42200-108 Administrative Assistant	\$24.86	\$0.00
E 101-41110-123 Medicare	\$13.86	\$0.00
E 101-43100-122 FICA-Social Security	\$206.78	\$0.00
E 101-41410-101 City Administrator	\$36.82	\$0.00
E 101-41410-121 PERA	\$2.76	\$0.00
E 101-41410-122 FICA-Social Security	\$2.28	\$0.00
E 101-41410-123 Medicare	\$0.53	\$0.00
E 101-41800-101 City Administrator	\$191.48	\$0.00
E 101-41800-105 Finance/Billing Clerk/Admin	\$669.77	\$0.00
E 101-41800-108 Administrative Assistant	\$292.10	\$0.00
E 101-41800-121 PERA	\$86.51	\$0.00
E 101-41800-122 FICA-Social Security	\$69.69	\$0.00
E 101-41800-123 Medicare	\$16.29	\$0.00
E 101-41800-131 Health Insurance	\$284.71	\$0.00
E 101-42200-101 City Administrator	\$44.19	\$0.00
E 101-41110-122 FICA-Social Security	\$59.29	\$0.00
E 602-49490-123 Medicare	\$26.10	\$0.00
E 101-43100-109 Public Works Maintenance	\$1,069.12	\$0.00
E 601-49440-108 Administrative Assistant	\$124.30	\$0.00
E 601-49440-109 Public Works Maintenance	\$308.40	\$0.00
E 601-49440-121 PERA	\$115.74	\$0.00
E 601-49440-122 FICA-Social Security	\$95.00	\$0.00
E 601-49440-123 Medicare	\$22.21	\$0.00
E 601-49440-131 Health Insurance	\$280.40	\$0.00
E 602-49490-101 City Administrator	\$73.65	\$0.00
E 602-49490-102 Public Works Director	\$476.41	\$0.00
E 602-49490-105 Finance/Billing Clerk/Admin	\$728.62	\$0.00
E 602-49490-108 Administrative Assistant	\$186.45	\$0.00
E 602-49490-109 Public Works Maintenance	\$349.52	\$0.00
E 601-49440-102 Public Works Director	\$420.36	\$0.00
E 602-49490-122 FICA-Social Security	\$111.62	\$0.00
E 601-49440-101 City Administrator	\$73.65	\$0.00
E 602-49490-131 Health Insurance	\$329.71	\$0.00
E 602-49490-331 Hotel,Meal,Prkg & Mileage Reim	\$28.00	\$0.00
G 101-10600 Cash	\$0.00	\$5,100.75
G 101-21701 Federal Withholding	\$0.00	\$1,512.56

CITY OF ROCKVILLE
Journal Entries

04/08/21 3:38 PM
Page 9

Current Period: FEBRUARY 2021

G 101-21702 State Withholding	\$0.00	\$524.41
G 101-21703 FICA/Medicare Withholding	\$0.00	\$1,988.54
G 101-21704 PERA	\$0.00	\$1,762.07
G 101-21705 Health Insurance	\$0.00	\$144.83
G 101-21706 City Portion Health Ins	\$0.00	\$1,158.63
G 101-21709 Short/Long-Term Disability	\$0.00	\$32.48
G 221-10600 Cash	\$0.00	\$8.77
G 601-10600 Cash	\$0.00	\$2,056.59
E 602-49490-121 PERA	\$136.11	\$0.00
E 101-46300-105 Finance/Billing Clerk/Admin	\$280.24	\$0.00
E 101-43100-123 Medicare	\$48.37	\$0.00
E 101-43100-131 Health Insurance	\$203.51	\$0.00
E 101-43100-220 Repair/Operating Expense	\$436.77	\$0.00
E 101-45122-101 City Administrator	\$92.06	\$0.00
E 101-45122-102 Public Works Director	\$371.32	\$0.00
E 101-45122-105 Finance/Billing Clerk/Admin	\$14.01	\$0.00
E 101-45122-108 Administrative Assistant	\$9.32	\$0.00
E 101-45122-109 Public Works Maintenance	\$292.98	\$0.00
E 101-45122-121 PERA	\$58.47	\$0.00
E 101-45122-122 FICA-Social Security	\$49.61	\$0.00
E 101-45122-123 Medicare	\$11.60	\$0.00
E 101-45122-131 Health Insurance	\$29.42	\$0.00
E 601-49440-105 Finance/Billing Clerk/Admin	\$616.53	\$0.00
E 101-46300-102 Public Works Director	\$7.01	\$0.00
G 602-10600 Cash	\$0.00	\$2,446.19
E 101-46300-108 Administrative Assistant	\$348.04	\$0.00
E 101-46300-109 Public Works Maintenance	\$5.14	\$0.00
E 101-46300-121 PERA	\$190.56	\$0.00
E 101-46300-122 FICA-Social Security	\$161.17	\$0.00
E 101-46300-123 Medicare	\$37.70	\$0.00
E 101-46300-131 Health Insurance	\$193.64	\$0.00
E 221-41000-101 City Administrator	\$3.68	\$0.00
E 221-41000-105 Finance/Billing Clerk/Admin	\$2.80	\$0.00
E 221-41000-121 PERA	\$0.49	\$0.00
E 221-41000-122 FICA-Social Security	\$0.38	\$0.00
E 221-41000-123 Medicare	\$0.10	\$0.00
E 221-41000-131 Health Insurance	\$1.32	\$0.00
E 101-46300-101 City Administrator	\$1,900.12	\$0.00
Transaction Date 2/11/2021	Total	\$16,735.82
		\$16,735.82

Fund Summary

	Debit	Credit	Difference
Refer -1 101 GENERAL FUND	\$12,224.27	\$12,224.27	In Balance
221 LAKE IMPROVEMENT DISTRIC	\$8.77	\$8.77	In Balance
601 WATER FUND	\$2,056.59	\$2,056.59	In Balance
602 SEWER FUND	\$2,446.19	\$2,446.19	In Balance

For each fund the Debits MUST equal Credits to be In Balance.

Batch Name 021721JE

Refer 93 Retainage 210th Street Project			
G 215-20300 Contract & Retainage Payable	\$0.00	\$16,162.88	
E 215-43100-590 Capital Outlay	\$16,162.88	\$0.00	
Transaction Date 2/17/2021	Total	\$16,162.88	\$16,162.88

CITY OF ROCKVILLE
Journal Entries

04/08/21 3:38 PM
Page 10

Current Period: FEBRUARY 2021

Fund Summary

		Debit	Credit	Difference
Refer 93	215 ROAD MAINTENANCE FUND	\$16,162.88	\$16,162.88	In Balance

For each fund the Debits MUST equal Credits to be In Balance.

Batch Name 021721UBREV

Refer	99 Ub Rec.		Debit	Credit
	R 601-49440-37100 Water Sales		\$34,112.05	\$0.00
	R 602-49490-37200 Swr Sales-Core City		\$18,608.57	\$0.00
	R 602-49490-37207 Sewer CBOD TSS PHOS		\$34,324.22	\$0.00
	R 602-49490-36240 Ref/Reimb		\$5,991.00	\$0.00
	R 602-49490-37205 Swr Sales-Lakes Area		\$28,656.02	\$0.00
	G 601-11500 Accounts Receivable		\$0.00	\$34,112.05
	G 602-11500 Accounts Receivable		\$0.00	\$87,579.81
Transaction Date	2/17/2021		Total	\$121,691.86
				\$121,691.86

Fund Summary

		Debit	Credit	Difference
Refer 99	601 WATER FUND	\$34,112.05	\$34,112.05	In Balance
	602 SEWER FUND	\$87,579.81	\$87,579.81	In Balance

For each fund the Debits MUST equal Credits to be In Balance.

Batch Name 022321CERTUNP

Refer	103 Resolution 2020-46 Unpaid Rev		Debit	Credit
	G 601-11500 Accounts Receivable		\$0.00	\$786.36
	G 602-11500 Accounts Receivable		\$0.00	\$1,201.18
	R 601-49440-37100 Water Sales		\$503.36	\$0.00
	R 601-49440-37180 Core Water Meters		\$218.00	\$0.00
	R 601-49440-34304 Labor/Equipment Charge		\$35.00	\$0.00
	R 601-49440-34110 Administrative Review/Service		\$30.00	\$0.00
	R 602-49490-37205 Swr Sales-Lakes Area		\$822.93	\$0.00
	R 602-49490-37200 Swr Sales-Core City		\$378.25	\$0.00
Transaction Date	2/23/2021		Total	\$1,987.54
				\$1,987.54

Fund Summary

		Debit	Credit	Difference
Refer 103	601 WATER FUND	\$786.36	\$786.36	In Balance
	602 SEWER FUND	\$1,201.18	\$1,201.18	In Balance

For each fund the Debits MUST equal Credits to be In Balance.

Batch Name 022421JE

Refer	-1 Labor Distribution		Debit	Credit
	E 101-42500-131 Health Insurance		\$1.50	\$0.00
	E 101-42200-108 Administrative Assistant		\$24.86	\$0.00
	E 101-42200-109 Public Works Maintenance		\$15.42	\$0.00
	E 101-42200-121 PERA		\$12.11	\$0.00
	E 101-42200-122 FICA-Social Security		\$9.99	\$0.00
	E 101-42200-123 Medicare		\$2.34	\$0.00
	E 101-42200-131 Health Insurance		\$2.93	\$0.00
	E 101-42200-220 Repair/Operating Expense		\$627.75	\$0.00
	E 101-42500-101 City Administrator		\$36.82	\$0.00
	E 101-42500-105 Finance/Billing Clerk/Admin		\$7.01	\$0.00

CITY OF ROCKVILLE
Journal Entries

04/08/21 3:38 PM
Page 11

Current Period: FEBRUARY 2021

E 101-42500-108 Administrative Assistant	\$31.07	\$0.00
E 101-42500-121 PERA	\$5.62	\$0.00
E 101-41000-101 City Administrator	\$228.31	\$0.00
E 101-42500-123 Medicare	\$1.10	\$0.00
E 101-42200-101 City Administrator	\$44.19	\$0.00
E 101-42800-101 City Administrator	\$7.36	\$0.00
E 101-42800-102 Public Works Director	\$7.01	\$0.00
E 101-42800-105 Finance/Billing Clerk/Admin	\$7.01	\$0.00
E 101-42800-109 Public Works Maintenance	\$5.14	\$0.00
E 101-42800-121 PERA	\$1.99	\$0.00
E 101-42800-122 FICA-Social Security	\$1.66	\$0.00
E 101-42800-123 Medicare	\$0.39	\$0.00
E 101-42800-131 Health Insurance	\$0.68	\$0.00
E 101-43100-101 City Administrator	\$147.30	\$0.00
E 101-43100-102 Public Works Director	\$1,471.26	\$0.00
E 101-43100-104 Seasonal/Temp/Committee	\$126.00	\$0.00
E 101-43100-105 Finance/Billing Clerk/Admin	\$287.25	\$0.00
E 101-42500-122 FICA-Social Security	\$4.71	\$0.00
E 101-41110-131 Health Insurance	\$34.50	\$0.00
E 101-41000-102 Public Works Director	\$28.02	\$0.00
E 101-41000-105 Finance/Billing Clerk/Admin	\$105.09	\$0.00
E 101-41000-108 Administrative Assistant	\$164.70	\$0.00
E 101-41000-109 Public Works Maintenance	\$10.28	\$0.00
E 101-41000-121 PERA	\$40.22	\$0.00
E 101-41000-122 FICA-Social Security	\$33.63	\$0.00
E 101-41000-123 Medicare	\$7.87	\$0.00
E 101-41000-131 Health Insurance	\$12.30	\$0.00
E 101-41110-101 City Administrator	\$846.95	\$0.00
E 101-41110-105 Finance/Billing Clerk/Admin	\$28.02	\$0.00
E 101-41110-108 Administrative Assistant	\$49.72	\$0.00
E 101-41110-121 PERA	\$69.35	\$0.00
E 101-42200-105 Finance/Billing Clerk/Admin	\$56.05	\$0.00
E 101-41110-123 Medicare	\$13.86	\$0.00
E 101-42200-102 Public Works Director	\$21.02	\$0.00
E 101-41410-101 City Administrator	\$36.82	\$0.00
E 101-41410-121 PERA	\$2.76	\$0.00
E 101-41410-122 FICA-Social Security	\$2.28	\$0.00
E 101-41410-123 Medicare	\$0.53	\$0.00
E 101-41800-101 City Administrator	\$191.48	\$0.00
E 101-41800-105 Finance/Billing Clerk/Admin	\$669.77	\$0.00
E 101-41800-108 Administrative Assistant	\$292.10	\$0.00
E 101-41800-121 PERA	\$86.51	\$0.00
E 101-41800-122 FICA-Social Security	\$69.69	\$0.00
E 101-41800-123 Medicare	\$16.29	\$0.00
E 101-41800-131 Health Insurance	\$7.80	\$0.00
E 101-43100-121 PERA	\$224.03	\$0.00
E 101-41110-122 FICA-Social Security	\$59.29	\$0.00
E 602-49490-122 FICA-Social Security	\$111.62	\$0.00
E 101-43100-108 Administrative Assistant	\$12.43	\$0.00
E 601-49440-105 Finance/Billing Clerk/Admin	\$616.53	\$0.00
E 601-49440-108 Administrative Assistant	\$124.30	\$0.00
E 601-49440-109 Public Works Maintenance	\$308.40	\$0.00
E 601-49440-121 PERA	\$115.74	\$0.00
E 601-49440-122 FICA-Social Security	\$95.00	\$0.00

CITY OF ROCKVILLE

Journal Entries

Current Period: FEBRUARY 2021

E 601-49440-123 Medicare	\$22.21	\$0.00
E 601-49440-131 Health Insurance	\$25.50	\$0.00
E 602-49490-101 City Administrator	\$73.65	\$0.00
E 602-49490-102 Public Works Director	\$476.41	\$0.00
E 602-49490-105 Finance/Billing Clerk/Admin	\$728.62	\$0.00
E 602-49490-108 Administrative Assistant	\$186.45	\$0.00
E 601-49440-101 City Administrator	\$73.65	\$0.00
E 602-49490-121 PERA	\$136.11	\$0.00
E 221-41000-131 Health Insurance	\$0.16	\$0.00
E 602-49490-123 Medicare	\$26.10	\$0.00
E 602-49490-131 Health Insurance	\$28.47	\$0.00
E 602-49490-331 Hotel,Meal,Prkg & Mileage Reim	\$50.40	\$0.00
G 101-10600 Cash	\$0.00	\$5,722.51
G 101-21701 Federal Withholding	\$0.00	\$1,509.35
G 101-21702 State Withholding	\$0.00	\$504.54
G 101-21703 FICA/Medicare Withholding	\$0.00	\$1,963.74
G 101-21704 PERA	\$0.00	\$1,762.07
G 101-21705 Health Insurance	\$0.00	\$144.83
G 101-21709 Short/Long-Term Disability	\$0.00	\$32.48
G 221-10600 Cash	\$0.00	\$7.61
G 601-10600 Cash	\$0.00	\$1,801.69
E 602-49490-109 Public Works Maintenance	\$349.52	\$0.00
E 101-46300-102 Public Works Director	\$7.01	\$0.00
G 602-10600 Cash	\$0.00	\$2,167.35
E 101-43100-122 FICA-Social Security	\$196.73	\$0.00
E 101-43100-123 Medicare	\$46.02	\$0.00
E 101-43100-131 Health Insurance	\$84.75	\$0.00
E 101-45122-101 City Administrator	\$92.06	\$0.00
E 101-45122-102 Public Works Director	\$371.32	\$0.00
E 101-45122-105 Finance/Billing Clerk/Admin	\$14.01	\$0.00
E 101-45122-108 Administrative Assistant	\$9.32	\$0.00
E 101-45122-109 Public Works Maintenance	\$292.98	\$0.00
E 101-45122-121 PERA	\$58.47	\$0.00
E 101-45122-122 FICA-Social Security	\$49.61	\$0.00
E 101-45122-123 Medicare	\$11.60	\$0.00
E 601-49440-102 Public Works Director	\$420.36	\$0.00
E 101-46300-101 City Administrator	\$1,900.12	\$0.00
E 101-43100-109 Public Works Maintenance	\$1,069.12	\$0.00
E 101-46300-105 Finance/Billing Clerk/Admin	\$280.24	\$0.00
E 101-46300-108 Administrative Assistant	\$348.04	\$0.00
E 101-46300-109 Public Works Maintenance	\$5.14	\$0.00
E 101-46300-121 PERA	\$190.56	\$0.00
E 101-46300-122 FICA-Social Security	\$161.17	\$0.00
E 101-46300-123 Medicare	\$37.70	\$0.00
E 101-46300-131 Health Insurance	\$77.78	\$0.00
E 221-41000-101 City Administrator	\$3.68	\$0.00
E 221-41000-105 Finance/Billing Clerk/Admin	\$2.80	\$0.00
E 221-41000-121 PERA	\$0.49	\$0.00
E 221-41000-122 FICA-Social Security	\$0.38	\$0.00
E 221-41000-123 Medicare	\$0.10	\$0.00
E 101-45122-131 Health Insurance	\$23.63	\$0.00
Transaction Date 2/25/2021	Total	\$15,616.17
		\$15,616.17

CITY OF ROCKVILLE
Journal Entries

Current Period: FEBRUARY 2021

Fund Summary

		Debit	Credit	Difference
Refer -1	101 GENERAL FUND	\$11,639.52	\$11,639.52	In Balance
	221 LAKE IMPROVEMENT DISTRIC	\$7.61	\$7.61	In Balance
	601 WATER FUND	\$1,801.69	\$1,801.69	In Balance
	602 SEWER FUND	\$2,167.35	\$2,167.35	In Balance

For each fund the Debits MUST equal Credits to be In Balance.

Batch Name 030921JE

Refer	-1 Labor Distribution	Debit	Credit
E 101-42500-131	Health Insurance	\$4.40	\$0.00
E 101-41000-101	City Administrator	\$228.31	\$0.00
E 101-42200-108	Administrative Assistant	\$24.86	\$0.00
E 101-42200-109	Public Works Maintenance	\$15.42	\$0.00
E 101-42200-121	PERA	\$12.11	\$0.00
E 101-42200-122	FICA-Social Security	\$19.66	\$0.00
E 101-42200-123	Medicare	\$4.60	\$0.00
E 101-42200-131	Health Insurance	\$26.10	\$0.00
E 101-42200-220	Repair/Operating Expense	\$20.34	\$0.00
E 101-42500-101	City Administrator	\$36.82	\$0.00
E 101-42500-105	Finance/Billing Clerk/Admin	\$7.01	\$0.00
E 101-42500-108	Administrative Assistant	\$31.07	\$0.00
E 101-42500-121	PERA	\$5.62	\$0.00
E 101-42200-105	Finance/Billing Clerk/Admin	\$56.05	\$0.00
E 101-42500-123	Medicare	\$1.10	\$0.00
E 101-42200-102	Public Works Director	\$21.02	\$0.00
E 101-42800-101	City Administrator	\$7.36	\$0.00
E 101-42800-102	Public Works Director	\$7.01	\$0.00
E 101-42800-105	Finance/Billing Clerk/Admin	\$7.01	\$0.00
E 101-42800-109	Public Works Maintenance	\$5.14	\$0.00
E 101-42800-121	PERA	\$1.99	\$0.00
E 101-42800-122	FICA-Social Security	\$1.66	\$0.00
E 101-42800-123	Medicare	\$0.39	\$0.00
E 101-42800-131	Health Insurance	\$3.58	\$0.00
E 101-43100-101	City Administrator	\$147.30	\$0.00
E 101-43100-102	Public Works Director	\$1,471.26	\$0.00
E 101-43100-104	Seasonal/Temp/Committee	\$396.00	\$0.00
E 101-43100-105	Finance/Billing Clerk/Admin	\$287.25	\$0.00
E 101-42500-122	FICA-Social Security	\$4.71	\$0.00
E 101-41110-131	Health Insurance	\$46.09	\$0.00
E 101-41000-102	Public Works Director	\$28.02	\$0.00
E 101-41000-105	Finance/Billing Clerk/Admin	\$105.09	\$0.00
E 101-41000-108	Administrative Assistant	\$164.70	\$0.00
E 101-41000-109	Public Works Maintenance	\$10.28	\$0.00
E 101-41000-121	PERA	\$40.22	\$0.00
E 101-41000-122	FICA-Social Security	\$33.63	\$0.00
E 101-41000-123	Medicare	\$7.87	\$0.00
E 101-41000-131	Health Insurance	\$55.75	\$0.00
E 101-41110-101	City Administrator	\$846.95	\$0.00
E 101-41110-105	Finance/Billing Clerk/Admin	\$28.02	\$0.00
E 101-41110-108	Administrative Assistant	\$49.72	\$0.00
E 101-41110-121	PERA	\$69.35	\$0.00
E 101-42200-107	Fire Dept Wages	\$156.00	\$0.00

CITY OF ROCKVILLE
Journal Entries

04/08/21 3:38 PM
Page 14

Current Period: MARCH 2021

E 101-41110-123 Medicare	\$13.86	\$0.00
E 101-43100-121 PERA	\$224.03	\$0.00
E 101-41410-101 City Administrator	\$36.82	\$0.00
E 101-41410-121 PERA	\$2.76	\$0.00
E 101-41410-122 FICA-Social Security	\$2.28	\$0.00
E 101-41410-123 Medicare	\$0.53	\$0.00
E 101-41800-101 City Administrator	\$191.48	\$0.00
E 101-41800-105 Finance/Billing Clerk/Admin	\$669.77	\$0.00
E 101-41800-108 Administrative Assistant	\$292.10	\$0.00
E 101-41800-121 PERA	\$86.51	\$0.00
E 101-41800-122 FICA-Social Security	\$69.69	\$0.00
E 101-41800-123 Medicare	\$16.29	\$0.00
E 101-41800-131 Health Insurance	\$284.71	\$0.00
E 101-42200-101 City Administrator	\$44.19	\$0.00
E 101-41110-122 FICA-Social Security	\$59.29	\$0.00
E 602-49490-123 Medicare	\$26.10	\$0.00
E 601-49440-105 Finance/Billing Clerk/Admin	\$616.53	\$0.00
E 601-49440-108 Administrative Assistant	\$124.30	\$0.00
E 601-49440-109 Public Works Maintenance	\$308.40	\$0.00
E 601-49440-121 PERA	\$115.74	\$0.00
E 601-49440-122 FICA-Social Security	\$95.00	\$0.00
E 601-49440-123 Medicare	\$22.21	\$0.00
E 601-49440-131 Health Insurance	\$280.40	\$0.00
E 602-49490-101 City Administrator	\$73.65	\$0.00
E 602-49490-102 Public Works Director	\$476.41	\$0.00
E 602-49490-105 Finance/Billing Clerk/Admin	\$728.62	\$0.00
E 602-49490-108 Administrative Assistant	\$186.45	\$0.00
E 602-49490-109 Public Works Maintenance	\$349.52	\$0.00
E 101-43100-108 Administrative Assistant	\$12.43	\$0.00
E 602-49490-122 FICA-Social Security	\$111.62	\$0.00
E 221-41000-131 Health Insurance	\$1.32	\$0.00
E 602-49490-131 Health Insurance	\$329.71	\$0.00
E 602-49490-331 Hotel,Meal,Prkg & Mileage Reim	\$16.80	\$0.00
G 101-10600 Cash	\$0.00	\$4,926.81
G 101-21701 Federal Withholding	\$0.00	\$1,533.76
G 101-21702 State Withholding	\$0.00	\$504.54
G 101-21703 FICA/Medicare Withholding	\$0.00	\$2,028.90
G 101-21704 PERA	\$0.00	\$1,762.07
G 101-21705 Health Insurance	\$0.00	\$144.83
G 101-21706 City Portion Health Ins	\$0.00	\$1,158.63
G 101-21709 Short/Long-Term Disability	\$0.00	\$32.48
G 221-10600 Cash	\$0.00	\$8.77
G 601-10600 Cash	\$0.00	\$2,056.59
E 602-49490-121 PERA	\$136.11	\$0.00
E 101-46300-102 Public Works Director	\$7.01	\$0.00
G 602-10600 Cash	\$0.00	\$2,434.99
E 101-43100-122 FICA-Social Security	\$213.47	\$0.00
E 101-43100-123 Medicare	\$49.93	\$0.00
E 101-43100-131 Health Insurance	\$203.51	\$0.00
E 101-45122-101 City Administrator	\$92.06	\$0.00
E 101-45122-102 Public Works Director	\$371.32	\$0.00
E 101-45122-105 Finance/Billing Clerk/Admin	\$14.01	\$0.00
E 101-45122-108 Administrative Assistant	\$9.32	\$0.00
E 101-45122-109 Public Works Maintenance	\$292.98	\$0.00

CITY OF ROCKVILLE
Journal Entries

04/08/21 3:38 PM
Page 15

Current Period: MARCH 2021

E 101-45122-121 PERA	\$58.47	\$0.00
E 101-45122-122 FICA-Social Security	\$49.61	\$0.00
E 101-45122-123 Medicare	\$11.60	\$0.00
E 601-49440-102 Public Works Director	\$420.36	\$0.00
E 101-46300-101 City Administrator	\$1,900.12	\$0.00
E 601-49440-101 City Administrator	\$73.65	\$0.00
E 101-46300-105 Finance/Billing Clerk/Admin	\$280.24	\$0.00
E 101-46300-108 Administrative Assistant	\$348.04	\$0.00
E 101-46300-109 Public Works Maintenance	\$5.14	\$0.00
E 101-46300-121 PERA	\$190.56	\$0.00
E 101-46300-122 FICA-Social Security	\$161.17	\$0.00
E 101-46300-123 Medicare	\$37.70	\$0.00
E 101-46300-131 Health Insurance	\$193.64	\$0.00
E 221-41000-101 City Administrator	\$3.68	\$0.00
E 221-41000-105 Finance/Billing Clerk/Admin	\$2.80	\$0.00
E 221-41000-121 PERA	\$0.49	\$0.00
E 221-41000-122 FICA-Social Security	\$0.38	\$0.00
E 221-41000-123 Medicare	\$0.10	\$0.00
E 101-43100-109 Public Works Maintenance	\$1,069.12	\$0.00
E 101-45122-131 Health Insurance	\$29.42	\$0.00
Transaction Date 3/11/2021	Total	\$16,592.37
		\$16,592.37

Fund Summary

	Debit	Credit	Difference
Refer -1 101 GENERAL FUND	\$12,092.02	\$12,092.02	In Balance
221 LAKE IMPROVEMENT DISTRIC	\$8.77	\$8.77	In Balance
601 WATER FUND	\$2,056.59	\$2,056.59	In Balance
602 SEWER FUND	\$2,434.99	\$2,434.99	In Balance

For each fund the Debits MUST equal Credits to be In Balance.

Batch Name 032321JE

Refer	Debit	Credit
-1 Labor Distribution		
E 101-42500-131 Health Insurance	\$1.50	\$0.00
E 101-42200-108 Administrative Assistant	\$24.86	\$0.00
E 101-42200-109 Public Works Maintenance	\$15.42	\$0.00
E 101-42200-121 PERA	\$12.11	\$0.00
E 101-42200-122 FICA-Social Security	\$9.99	\$0.00
E 101-42200-123 Medicare	\$2.34	\$0.00
E 101-42200-131 Health Insurance	\$2.93	\$0.00
E 101-42200-332 Training	\$196.00	\$0.00
E 101-42500-101 City Administrator	\$36.82	\$0.00
E 101-42500-105 Finance/Billing Clerk/Admin	\$7.01	\$0.00
E 101-42500-108 Administrative Assistant	\$31.07	\$0.00
E 101-42500-121 PERA	\$5.62	\$0.00
E 101-41000-101 City Administrator	\$228.31	\$0.00
E 101-42500-123 Medicare	\$1.10	\$0.00
E 101-42200-101 City Administrator	\$44.19	\$0.00
E 101-42800-101 City Administrator	\$7.36	\$0.00
E 101-42800-102 Public Works Director	\$7.01	\$0.00
E 101-42800-105 Finance/Billing Clerk/Admin	\$7.01	\$0.00
E 101-42800-109 Public Works Maintenance	\$5.14	\$0.00
E 101-42800-121 PERA	\$1.99	\$0.00
E 101-42800-122 FICA-Social Security	\$1.66	\$0.00

CITY OF ROCKVILLE
Journal Entries

04/08/21 3:38 PM
Page 16

Current Period: MARCH 2021

E 101-42800-123 Medicare	\$0.39	\$0.00
E 101-42800-131 Health Insurance	\$0.68	\$0.00
E 101-43100-101 City Administrator	\$147.30	\$0.00
E 101-43100-102 Public Works Director	\$1,471.26	\$0.00
E 101-43100-104 Seasonal/Temp/Committee	\$999.00	\$0.00
E 101-43100-105 Finance/Billing Clerk/Admin	\$287.25	\$0.00
E 101-42500-122 FICA-Social Security	\$4.71	\$0.00
E 101-41110-131 Health Insurance	\$34.50	\$0.00
E 101-41000-102 Public Works Director	\$28.02	\$0.00
E 101-41000-105 Finance/Billing Clerk/Admin	\$105.09	\$0.00
E 101-41000-108 Administrative Assistant	\$164.70	\$0.00
E 101-41000-109 Public Works Maintenance	\$10.28	\$0.00
E 101-41000-121 PERA	\$40.22	\$0.00
E 101-41000-122 FICA-Social Security	\$33.63	\$0.00
E 101-41000-123 Medicare	\$7.87	\$0.00
E 101-41000-131 Health Insurance	\$12.30	\$0.00
E 101-41110-101 City Administrator	\$846.95	\$0.00
E 101-41110-105 Finance/Billing Clerk/Admin	\$28.02	\$0.00
E 101-41110-108 Administrative Assistant	\$49.72	\$0.00
E 101-41110-121 PERA	\$69.35	\$0.00
E 101-42200-105 Finance/Billing Clerk/Admin	\$56.05	\$0.00
E 101-41110-123 Medicare	\$13.86	\$0.00
E 101-42200-102 Public Works Director	\$21.02	\$0.00
E 101-41410-101 City Administrator	\$36.82	\$0.00
E 101-41410-121 PERA	\$2.76	\$0.00
E 101-41410-122 FICA-Social Security	\$2.28	\$0.00
E 101-41410-123 Medicare	\$0.53	\$0.00
E 101-41800-101 City Administrator	\$191.48	\$0.00
E 101-41800-105 Finance/Billing Clerk/Admin	\$669.77	\$0.00
E 101-41800-108 Administrative Assistant	\$292.10	\$0.00
E 101-41800-121 PERA	\$86.51	\$0.00
E 101-41800-122 FICA-Social Security	\$69.69	\$0.00
E 101-41800-123 Medicare	\$16.29	\$0.00
E 101-41800-131 Health Insurance	\$7.80	\$0.00
E 101-43100-121 PERA	\$224.03	\$0.00
E 101-41110-122 FICA-Social Security	\$59.29	\$0.00
E 602-49490-122 FICA-Social Security	\$111.62	\$0.00
E 101-43100-108 Administrative Assistant	\$12.43	\$0.00
E 601-49440-105 Finance/Billing Clerk/Admin	\$616.53	\$0.00
E 601-49440-108 Administrative Assistant	\$124.30	\$0.00
E 601-49440-109 Public Works Maintenance	\$308.40	\$0.00
E 601-49440-121 PERA	\$115.74	\$0.00
E 601-49440-122 FICA-Social Security	\$95.00	\$0.00
E 601-49440-123 Medicare	\$22.21	\$0.00
E 601-49440-131 Health Insurance	\$25.50	\$0.00
E 602-49490-101 City Administrator	\$73.65	\$0.00
E 602-49490-102 Public Works Director	\$476.41	\$0.00
E 602-49490-105 Finance/Billing Clerk/Admin	\$728.62	\$0.00
E 602-49490-108 Administrative Assistant	\$186.45	\$0.00
E 601-49440-101 City Administrator	\$73.65	\$0.00
E 602-49490-121 PERA	\$136.11	\$0.00
E 221-41000-131 Health Insurance	\$0.16	\$0.00
E 602-49490-123 Medicare	\$26.10	\$0.00
E 602-49490-131 Health Insurance	\$28.47	\$0.00

CITY OF ROCKVILLE
Journal Entries

04/08/21 3:38 PM
Page 17

Current Period: MARCH 2021

E 602-49490-331 Hotel,Meal,Prkg & Mileage Reim	\$28.00	\$0.00
G 101-10600 Cash	\$0.00	\$5,975.04
G 101-21701 Federal Withholding	\$0.00	\$1,603.35
G 101-21702 State Withholding	\$0.00	\$532.47
G 101-21703 FICA/Medicare Withholding	\$0.00	\$2,097.32
G 101-21704 PERA	\$0.00	\$1,762.07
G 101-21705 Health Insurance	\$0.00	\$144.83
G 101-21709 Short/Long-Term Disability	\$0.00	\$32.48
G 221-10600 Cash	\$0.00	\$7.61
G 601-10600 Cash	\$0.00	\$1,801.69
E 602-49490-109 Public Works Maintenance	\$349.52	\$0.00
E 101-46300-102 Public Works Director	\$7.01	\$0.00
G 602-10600 Cash	\$0.00	\$2,144.95
E 101-43100-122 FICA-Social Security	\$250.86	\$0.00
E 101-43100-123 Medicare	\$58.68	\$0.00
E 101-43100-131 Health Insurance	\$84.75	\$0.00
E 101-45122-101 City Administrator	\$92.06	\$0.00
E 101-45122-102 Public Works Director	\$371.32	\$0.00
E 101-45122-105 Finance/Billing Clerk/Admin	\$14.01	\$0.00
E 101-45122-108 Administrative Assistant	\$9.32	\$0.00
E 101-45122-109 Public Works Maintenance	\$292.98	\$0.00
E 101-45122-121 PERA	\$58.47	\$0.00
E 101-45122-122 FICA-Social Security	\$49.61	\$0.00
E 101-45122-123 Medicare	\$11.60	\$0.00
E 601-49440-102 Public Works Director	\$420.36	\$0.00
E 101-46300-101 City Administrator	\$1,900.12	\$0.00
E 101-43100-109 Public Works Maintenance	\$1,069.12	\$0.00
E 101-46300-105 Finance/Billing Clerk/Admin	\$280.24	\$0.00
E 101-46300-108 Administrative Assistant	\$348.04	\$0.00
E 101-46300-109 Public Works Maintenance	\$5.14	\$0.00
E 101-46300-121 PERA	\$190.56	\$0.00
E 101-46300-122 FICA-Social Security	\$161.17	\$0.00
E 101-46300-123 Medicare	\$37.70	\$0.00
E 101-46300-131 Health Insurance	\$77.78	\$0.00
E 221-41000-101 City Administrator	\$3.68	\$0.00
E 221-41000-105 Finance/Billing Clerk/Admin	\$2.80	\$0.00
E 221-41000-121 PERA	\$0.49	\$0.00
E 221-41000-122 FICA-Social Security	\$0.38	\$0.00
E 221-41000-123 Medicare	\$0.10	\$0.00
E 101-45122-131 Health Insurance	\$23.63	\$0.00
Transaction Date 3/25/2021	Total	\$16,101.81
		\$16,101.81

Fund Summary

		Debit	Credit	Difference
Refer -1	101 GENERAL FUND	\$12,147.56	\$12,147.56	In Balance
	221 LAKE IMPROVEMENT DISTRIC	\$7.61	\$7.61	In Balance
	601 WATER FUND	\$1,801.69	\$1,801.69	In Balance
	602 SEWER FUND	\$2,144.95	\$2,144.95	In Balance

For each fund the Debits MUST equal Credits to be In Balance.

Building Permits: March 2021

Parcel #	REASON	ADDRESS	DATE	PERMIT #	Valuation	Permit \$	Review	SSC	Fees
76.41741.0045	Fireplace Insert	505 Walnut St	3/10/2021	2021-00006	\$ 8,000.00	\$ 40.00	\$ -	\$ 1.00	\$ 41.00
76.41613.0200	Windows/Door Replacement	24537 Co Rd 138	3/17/2021	2021-00007	\$ 17,543.00	\$ 35.00	\$ -	\$ 1.00	\$ 36.00
76.42170.0037	New Home Construction	8140 Co Rd 141	3/26/2021	2021-00020	\$ 375,000.00	\$ 2,062.50	\$ 1,340.63	\$ 187.50	\$ 3,590.63
76.41850.0203	New Home Construction	25739 Hilltop Ct	3/26/2021	2021-00021	\$ 408,000.00	\$ 2,244.00	\$ 1,458.60	\$ 204.00	\$ 3,906.60
76.41850.0203	Mechanical	25739 Hilltop Ct	3/26/2021	2021-00022	\$ -	\$ 75.00	\$ -	\$ 1.00	\$ 76.00
76.41850.0203	Plumbing	25739 Hilltop Ct	3/26/2021	2021-00023	\$ -	\$ 75.00	\$ -	\$ 1.00	\$ 76.00

ROCKVILLE ACTIVITY

March 2021

TOTAL HOURS: 37

***(SEE ATTACHED ACTIVITY LIST FOR
DETAILS)***

Actual_Incid_City	Call_Number	Unit	Date_Received	Complete	Narrative
ROCKVILLE	21017722	2567	03/01/2021 13:02:30	03/01/2021 14:05:31	[03/01/2021 14:05:28 : MOB : 2567] - - PATROLLED RESIDENTIAL AREAS, LOCAL BUSINESSES AND RURAL / COUNTY ROADS OF COMMUNITY. - ALL APPEARED NORMAL, NO SUSPICIOUS ACTIVITY AFOOT. - START OF CONTRACT - 1302. - END OF CONTRACT - 1402. - TOTAL CONTRACT TIME: 1 HOUR.
ROCKVILLE	21017917	2577	03/02/2021 04:24:54	03/02/2021 05:42:14	[03/02/2021 05:40:23 : MOB : 2577] OKERSTROM -1 HOUR OF CONTRACT -PATROLLED ROCKVILLE AND COUNTY PARK [03/02/2021 05:13:54 : MOB : 2577] 0506 [03/02/2021 04:50:26 : pos4 : 01CLJAEGER] DISPATCHED TO UNWANTED 0450
ROCKVILLE	21018450	2567	03/03/2021 15:41:28	03/03/2021 16:40:35	[03/03/2021 16:40:32 : MOB : 2567] - PATROLLED RESIDENTIAL AREAS, LOCAL BUSINESSES AND RURAL / COUNTY ROADS OF COMMUNITY. - ALL APPEARED NORMAL, NO SUSPICIOUS ACTIVITY AFOOT. - START OF CONTRACT - 1541. - END OF CONTRACT - 1641. - TOTAL CONTRACT TIME: 1 HOUR.
ROCKVILLE	21018686	2587	03/04/2021 14:16:01	03/04/2021 15:24:38	[03/04/2021 15:24:34 : MOB : 2587] -Fettig -1416-1516 hours -patrolled town site area -patrolled around grand lake and pleasant lake areas
ROCKVILLE	21019061	2568	03/05/2021 17:35:44	03/05/2021 21:48:20	[03/05/2021 21:48:03 : MOB : 2568] LUST -CONTRACT COMPLETED IN TWO PARTS 1735-1805 2115-2145 -ON ICR 21019056 FOR FIRST HALF HOUR-BHEALTH CALL -2ND HALF MISC AREAS

Actual_Incid_City	Call_Number	Unit	Date_Received	Complete	Narrative
ROCKVILLE	21019289	2587	03/06/2021 10:21:47	03/06/2021 11:34:25	[03/06/2021 11:32:27 : MOB : 2587] DEP FETTIG -PATROLED DOWNTOWN AND GRAND LAKE AREA -CALM MORNING; NOTHING TO REPORT
ROCKVILLE	21019730	2555	03/07/2021 18:56:09	03/07/2021 20:04:37	[03/07/2021 20:04:20 : MOB : 2555] -grand lk area -pleasant lake area -end 2004 -total time 1 hour c.schwegel [03/07/2021 19:08:31 : MOB : 2555] -res areas around townsite [03/07/2021 19:05:24 : MOB : 2555] birch st apts [03/07/2021 19:01:05 : MOB : 2555] co park/eagle park [03/07/2021 18:58:11 : MOB : 2555] start 1858
ROCKVILLE	21019873	2511	03/08/2021 10:37:40	03/08/2021 14:00:00	[03/08/2021 13:59:54 : MOB : 2511] 1 hr completed between Deputy Wells and myself 1 hr completed sgt klein [03/08/2021 13:30:29 : MOB : 2511] back on contract [03/08/2021 11:13:02 : pos6 : 01TLDINND0] SENT TO SUICIDAL CALL IN ST AUGUSTA
ROCKVILLE	21020256	2559	03/09/2021 11:57:03	03/09/2021 13:01:34	[03/09/2021 12:55:25 : MOB : 2559] patrolled downtown and residential areas

Actual_Incid_City	Call_Number	Unit	Date_Received	Complete	Narrative
ROCKVILLE	21020677	2547	03/10/2021 10:14:10	03/10/2021 12:04:23	<p>[03/10/2021 12:03:34 : MOB : 2547] WELLS-1015-1045 -CHECKED AREAS AROUND TOWNSITE -DOWNTOWN -CO PARK -NEIGHBORHOODS -BUSINESSES NEAR BROADWAY ST W -1052, CLEARED FOR A WELF IN ST AUGUSTA -RETURNED 1140 1140-1202 -CHECKED AREAS AROUND PLEASANT LK -LK RD -CR6 -FIRE HALL -ONE HR COMPLETE</p> <p>[03/10/2021 11:45:05 : MOB : 2547] BACK 1140</p> <p>[3/10/2021 11:42:22 : pos6 : 01LLSWANSO] CLEARED AT 1052 TO RESPOND TO AN EMERGENCY CALL</p>
ROCKVILLE	21020857	2557	03/10/2021 22:23:37	03/10/2021 23:23:17	<p>[03/10/2021 23:22:21 : MOB : 2557] ringness -contract assigned for 1900 hours -start at 2223 becuse of calls -townsite -rockville county park -pine st, rausch lk rd, agate beach rd, co rd 8 -lake rd -conract done at 2324 -one hour done</p>
ROCKVILLE	21020898	2577	03/11/2021 03:17:17	03/11/2021 04:18:12	<p>[03/11/2021 04:18:03 : MOB : 2577] OKERSTROM -STARTED 0317, ENDED 0417, 1 HOUR -PATROLLED ROCKVILLE</p>
ROCKVILLE	21021317	2547	03/12/2021 12:53:43	03/12/2021 14:00:52	<p>[03/12/2021 14:00:27 : MOB : 2547] WELLS-1250-1320 -CHECKED AREAS AROUND TOWNSITE</p>

Actual_Incid_City	Call_Number	Unit	Date_Received	Complete	Narrative
ROCKVILLE	21021409	2557	03/12/2021 18:30:25	03/12/2021 19:31:41	[03/12/2021 19:31:29 : MOB : 2557] ringness -contract assigned for 1800 to 1900 -started at 1830 becuse of calls -patrolled the townsite -21021413 traffic stop -rockville county park -one hour done at 1931
ROCKVILLE	21021573	2515	03/13/2021 02:01:22	03/13/2021 03:25:18	[03/13/2021 03:25:13 : MOB : 2515] -COMPLETED 1 HOUR CONTRACT -PATROLLED RESIDENTIAL AREAS -ALL WAS QUIET -STOPPED 1 VEHICLE FOR SPEED ON BROADWAY ST - VERBAL WARNING -SGT WIDMER
ROCKVILLE	21021629	2544	03/13/2021 10:17:04	03/13/2021 11:17:43	
ROCKVILLE	21022036	2544	03/14/2021 13:36:16	03/14/2021 14:36:56	
ROCKVILLE	21022373	2544	03/15/2021 15:19:19	03/15/2021 16:26:38	
ROCKVILLE	21022683	2544	03/16/2021 14:13:55	03/16/2021 15:23:17	
ROCKVILLE	21022783	2555	03/16/2021 19:58:52	03/16/2021 21:02:25	[03/16/2021 21:02:21 : MOB : 2555] -CO PARK/EAGLE PARK -DOWNTOWN/BAR AREA -BIRCH ST APTS -RES AREAS AROUND TOWNSITE -GRAND LK AREA -PLEASANT LK AREA -END 2058 -TOTAL 1 HOUR C.SCHWEGEL [03/16/2021 19:59:06 : MOB : 2555] START 1958

Actual_Incid_City	Call_Number	Unit	Date_Received	Complete	Narrative
ROCKVILLE	21023224	2551	03/17/2021 22:19:10	03/17/2021 23:32:02	[03/17/2021 23:31:59 : MOB : 2551] SALFER - 1 HOUR CONTRACT COMPLETE. 2219 TO 2319 HOURS. - NTR
ROCKVILLE	21023354	2548	03/18/2021 10:11:10	03/18/2021 11:13:53	[03/18/2021 11:13:37 : MOB : 2548] -STARTED CONTRACT LATE DUE TO CALLS. -PATROLLED TOWN, NO ISSUES.
ROCKVILLE	21023621	2558	03/19/2021 02:15:04	03/19/2021 03:16:00	[03/19/2021 03:15:34 : MOB : 2558] 0215-START OF CONTRACT 0215-0315-PATROLLED GRAND LK AREA, PLEASANT LK AREA AND TOWN SITE -NOTHING SUSP, NO TRAFFIC EXCEPT HWY 23, NO VIOL 0315-END OF CONTRACT TOTAL TIME OF CONTRACT - 1 HOUR
ROCKVILLE	21024052	2567	03/20/2021 11:13:02	03/20/2021 13:57:32	[03/20/2021 13:57:29 : MOB : 2567] - PATROLLED RESIDENTIAL AREAS, LOCAL BUSINESSES AND RURAL / COUNTY ROADS OF COMMUNITY. - ALL APPEARED NORMAL, NO SUSPICIOUS ACTIVITY AFOOT. - START OF CONTRACT - 1113. - END OF CONTRACT - 1356. - CONTR INTERRUPTED DUE TO CRASH W/ INJURIES CALL IN WAKEFIELD TWP. - TOTAL CONTRACT TIME: 1 HOUR. [3/20/2021 11:48:49 : pos5 : 01LLSWANSO] CLEARED TO GO TO CRASH W/INJURY
ROCKVILLE	21024223	2553	03/20/2021 19:38:02	03/20/2021 20:38:29	[03/20/2021 20:38:23 : MOB : 2553] - CONTR STARTED AT 1938 - CONTR ENDED 2038 HAGSTROM
ROCKVILLE	21024436	2548	03/21/2021 08:57:42	03/21/2021 09:57:55	[03/21/2021 09:57:41 : MOB : 2548] -PATROLLED THROUGH OUT TOWN. -NO ISSUES. -REMOVED A PIPE ON HWY 23// CR 8.

Actual_Incid_City	Call_Number	Unit	Date_Received	Complete	Narrative
ROCKVILLE	21024922	2514	03/22/2021 22:16:47	03/22/2021 23:24:07	[03/22/2021 23:15:59 : MOB : 2514] meland patrolled city ran radar on broadway st checked city hall checked fire hall
ROCKVILLE	21025071	2545	03/23/2021 13:18:52	03/23/2021 14:32:57	[03/23/2021 14:32:43 : MOB : 2545] -lena ln, lake rd, cr 47 -ended contract at 1430 hours. [03/23/2021 13:57:25 : MOB : 2545] -berg street, alvin ct, [03/23/2021 13:44:22 : MOB : 2545] -started contract at 1320 hours. late due to meeting and calls -patrolled eagles park, broadway street, cr 47, lake rd,
ROCKVILLE	21025303	2578	03/24/2021 04:01:00	03/24/2021 05:03:37	[03/24/2021 05:03:33 : MOB : 2578] -1 HR ROCKVILLE CONTR. 0401-0501 HRS -PATROLLED THE CITY -SLOWLY WAKING UP BRAEGELMANN [03/24/2021 04:22:49 : MOB : 2578] -21025304 SUSV AT AJ REPAIRABLE
ROCKVILLE	21025531	2579	03/24/2021 17:55:25	03/24/2021 19:26:06	[03/24/2021 19:23:18 : MOB : 2579] ROMSTAD 2579 - ONE HOUR CONTACT - 1755 - 1825 HRS - 1855 - 1925 HRS [03/24/2021 19:22:25 : MOB : 2579] - ASSISTED COLD SPRING PD ON A CALL DURING CONTRACT TIME [03/24/2021 19:21:36 : MOB : 2579] - ROUTINE PATROL - PATROLED TOWNSITE, STORAGE SHEDS, PLEASANT LAKE

Actual_Incid_City	Call_Number	Unit	Date_Received	Complete	Narrative
ROCKVILLE	21025758	2545	03/25/2021 12:20:30	03/25/2021 13:26:49	[03/25/2021 13:26:40 : MOB : 2545] -cottonwood st, checked out both parks -ended contract at 1325 hours. [03/25/2021 13:13:01 : MOB : 2545] -started contract at 1220 hours, -patrolled ahles rd, rausch lk rd, broadway st, john clark, caroline ln, othmar ln, walnut st,
ROCKVILLE	21026240	2556K9	03/26/2021 17:53:35	03/26/2021 19:02:13	[03/26/2021 19:01:40 : MOB : 2556K9] 1 HOUR CONTRACT. THUNSTEDT
ROCKVILLE	21026386	2569K9	03/27/2021 04:54:56	03/27/2021 05:56:34	[03/27/2021 05:56:26 : MOB : 2569K9] A JOHNSON -PATROLED RESIDENTIAL AREAS -STORAGE UNITS -FIREHALL -LAKE RD TO CR 6 -0454 TO 0554
ROCKVILLE	21026897	2546	03/28/2021 20:45:06	03/28/2021 21:45:59	[03/28/2021 21:45:50 : MOB : 2546] JENSEN -DROVE GRAND LAKE AREA AND DOWNTOWN ROCKVILLE NO REPORT
ROCKVILLE	21026948	2558	03/29/2021 04:48:24	03/29/2021 05:49:48	[03/29/2021 05:49:33 : MOB : 2558] 0448-START OF CONTRACT 0448-0548-PATROLLED GRAND LKK AREA, PLEASANT LK AREA AND TOWN SITE 0548-END OF CONTRACT TOTAL TIME OF CONTRACT - 1 HOUR
ROCKVILLE	21027453	2507	03/30/2021 20:23:25	03/30/2021 21:29:57	[03/30/2021 21:29:52 : MOB : 2507] COMPLETED 1 HOUR CONTRACT. PATROL CITY. NIEMI

Actual_Incid_City	Call_Number	Unit	Date_Received	Complete	Narrative
ROCKVILLE	21027594	2559	03/31/2021 09:04:37	03/31/2021 10:06:50	[03/31/2021 10:01:50 : MOB : 2559] patrolled downtown and residential areas

ALL CALLS - MARCH 2021

City	Date Received	Call Number	Complaint	Description
ROCKVILLE	03/05/2021 13:50:51	21018971	AL	ALARM
ROCKVILLE	03/09/2021 14:25:50	21020292	AL	ALARM
ROCKVILLE	03/24/2021 02:18:35	21025292	AL	ALARM
ROCKVILLE	03/02/2021 21:54:24	21018174	ASLT	ASSAULT
ROCKVILLE	03/12/2021 17:38:51	21021392	ASSTA	AGENCY ASSIST
ROCKVILLE	03/13/2021 19:09:29	21021793	ASSTA	AGENCY ASSIST
ROCKVILLE	03/18/2021 17:01:56	21023488	ASSTA	AGENCY ASSIST
ROCKVILLE	03/31/2021 11:13:55	21027625	ASSTA	AGENCY ASSIST
ROCKVILLE	03/05/2021 17:26:16	21019056	BHEALTH	BEHAVIORAL HEALTH
ROCKVILLE	03/21/2021 20:03:13	21024570	BURN	ILLEGAL BURNING
ROCKVILLE	03/27/2021 09:12:42	21026408	COMENG	COMMUNITY ENGAGEMENT
ROCKVILLE	03/28/2021 20:45:06	21026897	CONTR	CONTRACT
ROCKVILLE	03/29/2021 04:48:24	21026948	CONTR	CONTRACT
ROCKVILLE	03/31/2021 09:04:37	21027594	CONTR	CONTRACT
ROCKVILLE	03/27/2021 04:54:56	21026386	CONTR	CONTRACT
ROCKVILLE	03/30/2021 20:23:25	21027453	CONTR	CONTRACT
ROCKVILLE	03/24/2021 17:55:25	21025531	CONTR	CONTRACT
ROCKVILLE	03/25/2021 12:20:30	21025758	CONTR	CONTRACT
ROCKVILLE	03/26/2021 17:53:35	21026240	CONTR	CONTRACT
ROCKVILLE	03/20/2021 11:13:02	21024052	CONTR	CONTRACT
ROCKVILLE	03/20/2021 19:38:02	21024223	CONTR	CONTRACT
ROCKVILLE	03/21/2021 08:57:42	21024436	CONTR	CONTRACT
ROCKVILLE	03/24/2021 04:01:00	21025303	CONTR	CONTRACT
ROCKVILLE	03/22/2021 22:16:47	21024922	CONTR	CONTRACT
ROCKVILLE	03/23/2021 13:18:52	21025071	CONTR	CONTRACT
ROCKVILLE	03/15/2021 15:19:19	21022373	CONTR	CONTRACT
ROCKVILLE	03/16/2021 14:13:55	21022683	CONTR	CONTRACT
ROCKVILLE	03/16/2021 19:58:52	21022783	CONTR	CONTRACT
ROCKVILLE	03/17/2021 22:19:10	21023224	CONTR	CONTRACT
ROCKVILLE	03/18/2021 10:11:10	21023354	CONTR	CONTRACT
ROCKVILLE	03/19/2021 02:15:04	21023621	CONTR	CONTRACT
ROCKVILLE	03/05/2021 17:35:44	21019061	CONTR	CONTRACT
ROCKVILLE	03/06/2021 10:21:47	21019289	CONTR	CONTRACT
ROCKVILLE	03/07/2021 18:56:09	21019730	CONTR	CONTRACT
ROCKVILLE	03/08/2021 10:37:40	21019873	CONTR	CONTRACT
ROCKVILLE	03/09/2021 11:57:03	21020256	CONTR	CONTRACT
ROCKVILLE	03/01/2021 13:02:30	21017722	CONTR	CONTRACT
ROCKVILLE	03/02/2021 04:24:54	21017917	CONTR	CONTRACT
ROCKVILLE	03/03/2021 15:41:28	21018450	CONTR	CONTRACT
ROCKVILLE	03/04/2021 14:16:01	21018686	CONTR	CONTRACT
ROCKVILLE	03/13/2021 02:01:22	21021573	CONTR	CONTRACT
ROCKVILLE	03/13/2021 10:17:04	21021629	CONTR	CONTRACT
ROCKVILLE	03/14/2021 13:36:16	21022036	CONTR	CONTRACT
ROCKVILLE	03/12/2021 18:30:25	21021409	CONTR	CONTRACT
ROCKVILLE	03/12/2021 12:53:43	21021317	CONTR	CONTRACT
ROCKVILLE	03/10/2021 10:14:10	21020677	CONTR	CONTRACT
ROCKVILLE	03/10/2021 22:23:37	21020857	CONTR	CONTRACT
ROCKVILLE	03/11/2021 03:17:17	21020898	CONTR	CONTRACT
ROCKVILLE	03/09/2021 13:16:52	21020275	COURT	COURT
ROCKVILLE	03/14/2021 06:47:57	21021983	CRASH	ACCIDENT
ROCKVILLE	03/16/2021 05:36:38	21022562	CRASH	ACCIDENT
ROCKVILLE	03/12/2021 17:35:11	21021391	DOM	DOMESTIC
ROCKVILLE	03/06/2021 00:06:48	21019203	DOORCHK	DOOR CHECK(S)
ROCKVILLE	03/20/2021 03:20:28	21024006	DOORCHK	DOOR CHECK(S)
ROCKVILLE	03/18/2021 16:54:52	21023486	DRIVE	DRIVING COMPLAINT
ROCKVILLE	03/31/2021 11:05:38	21027624	DRIVE	DRIVING COMPLAINT
ROCKVILLE	03/26/2021 07:43:17	21026052	FIREB	FIRE BUILDING
ROCKVILLE	03/16/2021 00:39:33	21022529	FPATROL	FOOT PATROL
ROCKVILLE	03/08/2021 14:36:37	21019968	FPROP	FOUND PROPERTY

<u>City</u>	<u>Date_Received</u>	<u>Call_Number</u>	<u>Complaint</u>	<u>Description</u>
ROCKVILLE	03/15/2021 14:56:40	21022357	HARRORV	HARASSMENT RESTRAINING ORD
ROCKVILLE	03/14/2021 18:28:55	21022105	HAZ	HAZARD
ROCKVILLE	03/07/2021 14:02:50	21019642	HAZ	HAZARD
ROCKVILLE	03/26/2021 16:18:19	21026210	HAZ	HAZARD
ROCKVILLE	03/30/2021 19:38:26	21027444	INFO	MATTER OF INFORMATION
ROCKVILLE	03/19/2021 04:43:46	21023637	INFO	MATTER OF INFORMATION
ROCKVILLE	03/15/2021 10:36:34	21022271	INFO	MATTER OF INFORMATION
ROCKVILLE	03/11/2021 18:34:41	21021105	INFO	MATTER OF INFORMATION
ROCKVILLE	03/24/2021 23:25:52	21025616	K9ASST	CANINE ASSIST
ROCKVILLE	03/26/2021 23:53:40	21026348	K9TRAIN	CANINE TRAINING
ROCKVILLE	03/24/2021 00:21:22	21025281	K9TRAIN	CANINE TRAINING
ROCKVILLE	03/04/2021 23:41:39	21018817	K9TRAIN	CANINE TRAINING
ROCKVILLE	03/04/2021 04:48:33	21018583	LIGHTSON	LIGHTS ON PROGRAM
ROCKVILLE	03/24/2021 23:12:42	21025611	LIGHTSON	LIGHTS ON PROGRAM
ROCKVILLE	03/24/2021 18:20:16	21025536	MA	MOTORIST ASSIST
ROCKVILLE	03/19/2021 16:25:42	21023782	MA	MOTORIST ASSIST
ROCKVILLE	03/18/2021 09:56:12	21023352	MED	MEDICAL EMERGENCY
ROCKVILLE	03/17/2021 21:37:30	21023206	MED	MEDICAL EMERGENCY
ROCKVILLE	03/29/2021 14:44:33	21027074	MED	MEDICAL EMERGENCY
ROCKVILLE	03/06/2021 15:44:26	21019361	MED	MEDICAL EMERGENCY
ROCKVILLE	03/13/2021 05:02:21	21021600	MED	MEDICAL EMERGENCY
ROCKVILLE	03/24/2021 21:58:30	21025594	MEETING	ATTEND MEETING
ROCKVILLE	03/16/2021 14:36:29	21022695	MEETING	ATTEND MEETING
ROCKVILLE	03/13/2021 18:44:53	21021783	NOISE	NOISE COMPLAINT
ROCKVILLE	03/29/2021 16:44:24	21027120	PAPSV	PAPER SERVICE
ROCKVILLE	03/29/2021 17:00:53	21027124	PAPSV	PAPER SERVICE
ROCKVILLE	03/29/2021 17:12:06	21027126	PAPSV	PAPER SERVICE
ROCKVILLE	03/28/2021 23:39:04	21026926	PARKPAT	PARK PATROL
ROCKVILLE	03/18/2021 01:56:34	21023306	PARKPAT	PARK PATROL
ROCKVILLE	03/14/2021 04:44:58	21021975	PARKPAT	PARK PATROL
ROCKVILLE	03/10/2021 00:06:43	21020544	PARKPAT	PARK PATROL
ROCKVILLE	03/04/2021 04:39:45	21018582	PARKPAT	PARK PATROL
ROCKVILLE	03/01/2021 05:15:12	21017634	PARKPAT	PARK PATROL
ROCKVILLE	03/18/2021 22:40:54	21023591	ROADRAGE	ROAD RAGE
ROCKVILLE	03/21/2021 21:12:55	21024588	RW	REPORT WRITING
ROCKVILLE	03/03/2021 12:01:06	21018394	RW	REPORT WRITING
ROCKVILLE	03/05/2021 12:38:31	21018944	RW	REPORT WRITING
ROCKVILLE	03/04/2021 15:28:32	21018699	RW	REPORT WRITING
ROCKVILLE	03/19/2021 16:09:07	21023773	SBUS	SCHOOL BUS/SCHOOL VIOLATION
ROCKVILLE	03/27/2021 09:20:40	21026410	SD	SPECIAL DETAIL
ROCKVILLE	03/27/2021 10:38:04	21026424	SD	SPECIAL DETAIL
ROCKVILLE	03/30/2021 01:50:08	21027250	SUSV	SUSPICIOUS VEHICLE
ROCKVILLE	03/24/2021 04:10:10	21025304	SUSV	SUSPICIOUS VEHICLE
ROCKVILLE	03/24/2021 10:59:42	21025354	SUSV	SUSPICIOUS VEHICLE
ROCKVILLE	03/06/2021 22:55:03	21019507	SUSV	SUSPICIOUS VEHICLE
ROCKVILLE	03/11/2021 16:56:57	21021065	TOW	TOWED VEHICLE
ROCKVILLE	03/11/2021 15:00:45	21021028	TOW	TOWED VEHICLE
ROCKVILLE	03/11/2021 16:25:17	21021054	TRAFFIC STOP	TRAFFIC STOP
ROCKVILLE	03/09/2021 17:25:00	21020425	TRAFFIC STOP	TRAFFIC STOP
ROCKVILLE	03/11/2021 14:33:25	21021014	TRAFFIC STOP	TRAFFIC STOP
ROCKVILLE	03/11/2021 14:43:54	21021021	TRAFFIC STOP	TRAFFIC STOP
ROCKVILLE	03/12/2021 19:08:16	21021413	TRAFFIC STOP	TRAFFIC STOP
ROCKVILLE	03/15/2021 01:55:34	21022209	TRAFFIC STOP	TRAFFIC STOP
ROCKVILLE	03/13/2021 02:38:43	21021580	TRAFFIC STOP	TRAFFIC STOP
ROCKVILLE	03/13/2021 19:15:19	21021796	TRAFFIC STOP	TRAFFIC STOP
ROCKVILLE	03/14/2021 00:48:02	21021943	TRAFFIC STOP	TRAFFIC STOP
ROCKVILLE	03/14/2021 01:03:16	21021950	TRAFFIC STOP	TRAFFIC STOP
ROCKVILLE	03/06/2021 23:02:32	21019513	TRAFFIC STOP	TRAFFIC STOP
ROCKVILLE	03/06/2021 18:44:15	21019414	TRAFFIC STOP	TRAFFIC STOP
ROCKVILLE	03/06/2021 01:00:53	21019221	TRAFFIC STOP	TRAFFIC STOP
ROCKVILLE	03/06/2021 01:49:27	21019233	TRAFFIC STOP	TRAFFIC STOP
ROCKVILLE	03/05/2021 19:48:56	21019112	TRAFFIC STOP	TRAFFIC STOP
ROCKVILLE	03/05/2021 14:53:25	21018987	TRAFFIC STOP	TRAFFIC STOP

<u>City</u>	<u>Date_Received</u>	<u>Call_Number</u>	<u>Complaint</u>	<u>Description</u>
ROCKVILLE	03/05/2021 16:45:03	21019039	TRAFFIC STOP	TRAFFIC STOP
ROCKVILLE	03/03/2021 19:31:37	21018503	TRAFFIC STOP	TRAFFIC STOP
ROCKVILLE	03/02/2021 17:26:53	21018104	TRAFFIC STOP	TRAFFIC STOP
ROCKVILLE	03/01/2021 22:58:37	21017869	TRAFFIC STOP	TRAFFIC STOP
ROCKVILLE	03/24/2021 15:58:07	21025499	TRAFFIC STOP	TRAFFIC STOP
ROCKVILLE	03/24/2021 17:38:52	21025522	TRAFFIC STOP	TRAFFIC STOP
ROCKVILLE	03/24/2021 01:44:15	21025290	TRAFFIC STOP	TRAFFIC STOP
ROCKVILLE	03/18/2021 02:09:38	21023310	TRAFFIC STOP	TRAFFIC STOP
ROCKVILLE	03/19/2021 08:12:51	21023664	TRAFFIC STOP	TRAFFIC STOP
ROCKVILLE	03/19/2021 08:21:32	21023665	TRAFFIC STOP	TRAFFIC STOP
ROCKVILLE	03/16/2021 11:02:54	21022622	TRAFFIC STOP	TRAFFIC STOP
ROCKVILLE	03/30/2021 22:09:04	21027477	TRAFFIC STOP	TRAFFIC STOP
ROCKVILLE	03/31/2021 22:52:14	21027853	TRAFFIC STOP	TRAFFIC STOP
ROCKVILLE	03/24/2021 21:47:26	21025591	TRAFFIC STOP	TRAFFIC STOP
ROCKVILLE	03/24/2021 23:12:57	21025612	TRAFFIC STOP	TRAFFIC STOP
ROCKVILLE	03/25/2021 22:58:49	21025978	TRAFFIC STOP	TRAFFIC STOP
ROCKVILLE	03/26/2021 05:26:31	21026031	TRAFFIC STOP	TRAFFIC STOP
ROCKVILLE	03/31/2021 04:09:20	21027545	TRAFFIC STOP	TRAFFIC STOP
ROCKVILLE	03/15/2021 14:51:14	21022352	VDITCH	VEHICLE IN THE DITCH
ROCKVILLE	03/15/2021 14:53:11	21022353	VDITCH	VEHICLE IN THE DITCH
ROCKVILLE	03/03/2021 07:27:04	21018254	WARRANT	WARRANT
ROCKVILLE	03/25/2021 15:40:48	21025823	WARRANT	WARRANT
ROCKVILLE	03/31/2021 03:09:35	21027538	WELF	WELFARE CHECK
ROCKVILLE	03/04/2021 20:06:37	21018774	WELF	WELFARE CHECK
ROCKVILLE	03/08/2021 13:53:52	21019944	WELF	WELFARE CHECK
ROCKVILLE	03/12/2021 00:44:29	21021210	XPAT	EXTRA PATROL

STEARNS COUNTY CITATIONS

04/01/2021

<u>Offense Date</u>	<u>City</u>	<u>Officer Name</u>	<u>Citation Number</u>	<u>Case #</u>	<u>Statute</u>	<u>Charge</u>
03/07/2021 16:04:	Rockville	FETTIG ADAM	730021052916	21019682	169.14.5	TRAFFIC - SPEEDING - EXCEED Fals
03/31/2021 22:52:	Rockville	FETTIG ADAM	730021063302	21027853	169.14.2(a)(2)	TRAFFIC - SPEEDING - EXCEED Fals
03/15/2021 01:55:	Rockville	LUST MARK	730021052984	21022209	169.14.2(a)(2)	TRAFFIC - SPEEDING - EXCEED Fals
03/14/2021 01:06:	Rockville	MAYERS MATTHEW	730021061858	21021950	169.14.2(a)(2)	TRAFFIC - SPEEDING - EXCEED Fals
03/09/2021 17:25:	Rockville	MILNE ZACHARY	730021061356	21020425	169.14.2(a)	TRAFFIC - SPEEDING - EXCEED Fals
03/07/2021 16:04:	Rockville	ROMSTAD SCOTT	730021052917	21019685	169.14.5	TRAFFIC - SPEEDING - EXCEED Fals
03/11/2021 14:35:	Rockville	SIMON KEITH	730021064107	21021014	169.14.2(a)(3)	TRAFFIC - SPEEDING - EXCEED Fals
03/01/2021 23:06:	Rockville	SIMON KEITH	730021063846	21017869	168.09.4	EXPIRED REGISTRATION < 12 MONTHS Fals
03/01/2021 23:06:	Rockville	SIMON KEITH	730021063846	21017869	169.791.2(a)	INSURANCE - NO PROOF Fals
03/24/2021 23:12:	Rockville	WIDMER SHAWN	730021061663	21025612	171.24.2	DAR -DRIVING AFTER REVOCATION Fals
03/24/2021 23:12:	Rockville	WIDMER SHAWN	730021061663	21025612	151.40.1	POSSESSION OF HYPODERMIC NEEDLE Fals
03/30/2021 22:09:	Rockville	YOUNKIN NATHANIEI	730021063505	21027477	169.14.5	TRAFFIC - SPEEDING - EXCEED Fals
03/31/2021 04:09:	Rockville	YOUNKIN NATHANIEI	730021063506	21027545	169.791.2(a)	INSURANCE - NO PROOF Fals

TOTAL: 13

CONTRACT DATES - MARCH 2021

<u>Actual Incid</u>	<u>City</u>	<u>Date Received</u>	<u>Comp</u>	<u>Call Number</u>	<u>Complaint</u>	<u>First Unit</u>
ROCKVILLE		03/01/2021 13:02:30	14:05:31	21017722	CONTR	2567
ROCKVILLE		03/02/2021 04:24:54	05:42:14	21017917	CONTR	2577
ROCKVILLE		03/03/2021 15:41:28	16:40:35	21018450	CONTR	2567
ROCKVILLE		03/04/2021 14:16:01	15:24:38	21018686	CONTR	2587
ROCKVILLE		03/05/2021 17:35:44	21:48:20	21019061	CONTR	2568
ROCKVILLE		03/06/2021 10:21:47	11:34:25	21019289	CONTR	2587
ROCKVILLE		03/07/2021 18:56:09	20:04:37	21019730	CONTR	2555
ROCKVILLE		03/08/2021 10:37:40	14:00:00	21019873	CONTR	2511
ROCKVILLE		03/09/2021 11:57:03	13:01:34	21020256	CONTR	2559
ROCKVILLE		03/10/2021 10:14:10	12:04:23	21020677	CONTR	2547
ROCKVILLE		03/10/2021 22:23:37	23:23:17	21020857	CONTR	2557
ROCKVILLE		03/11/2021 03:17:17	04:18:12	21020898	CONTR	2577
ROCKVILLE		03/12/2021 12:53:43	14:00:52	21021317	CONTR	2547
ROCKVILLE		03/12/2021 18:30:25	19:31:41	21021409	CONTR	2557
ROCKVILLE		03/13/2021 02:01:22	03:25:18	21021573	CONTR	2515
ROCKVILLE		03/13/2021 10:17:04	11:17:43	21021629	CONTR	2544
ROCKVILLE		03/14/2021 13:36:16	14:36:56	21022036	CONTR	2544
ROCKVILLE		03/15/2021 15:19:19	16:26:38	21022373	CONTR	2544
ROCKVILLE		03/16/2021 14:13:55	15:23:17	21022683	CONTR	2544
ROCKVILLE		03/16/2021 19:58:52	21:02:25	21022783	CONTR	2555
ROCKVILLE		03/17/2021 22:19:10	23:32:02	21023224	CONTR	2551
ROCKVILLE		03/18/2021 10:11:10	11:13:53	21023354	CONTR	2548
ROCKVILLE		03/19/2021 02:15:04	03:16:00	21023621	CONTR	2558
ROCKVILLE		03/20/2021 11:13:02	13:57:32	21024052	CONTR	2567
ROCKVILLE		03/20/2021 19:38:02	20:38:29	21024223	CONTR	2553
ROCKVILLE		03/21/2021 08:57:42	09:57:55	21024436	CONTR	2548
ROCKVILLE		03/22/2021 22:16:47	23:24:07	21024922	CONTR	2514
ROCKVILLE		03/23/2021 13:18:52	14:32:57	21025071	CONTR	2545
ROCKVILLE		03/24/2021 04:01:00	05:03:37	21025303	CONTR	2578
ROCKVILLE		03/24/2021 17:55:25	19:26:06	21025531	CONTR	2579
ROCKVILLE		03/25/2021 12:20:30	13:26:49	21025758	CONTR	2545
ROCKVILLE		03/26/2021 17:53:35	19:02:13	21026240	CONTR	2556K9
ROCKVILLE		03/27/2021 04:54:56	05:56:34	21026386	CONTR	2569K9
ROCKVILLE		03/28/2021 20:45:06	21:45:59	21026897	CONTR	2546
ROCKVILLE		03/29/2021 04:48:24	05:49:48	21026948	CONTR	2558
ROCKVILLE		03/30/2021 20:23:25	21:29:57	21027453	CONTR	2507
ROCKVILLE		03/31/2021 09:04:37	10:06:50	21027594	CONTR	2559

February Duties for the Rockville Maintenance Department

Water System duties

- 1 Daily Well Readings (4 wells)
- 2 Minimum Weekly Water Testing Fluoride & Chlorine
- 3 Monthly Reports to MN Dept of Health
- 4 Final Meter Reading (as needed)
- 5 Repair meters, outside remotes, hydrants and chemical feed equipment
- 6 Install meters (as needed)
- 7 Water meter reading
- 8 Locates (as needed)
- 9 Empty garbages (if necessary)

Sewer system duties

- 1 Daily liftstation readings (5 liftstations)
- 2 Add enzymes to liftstation (as needed)
- 3 Test run generators monthly at different liftstations each month
- 4 Send monthly reports to Cold Spring
- 5 Do repairs to liftstations & grinderstations (as needed)
- 6 Locates (as needed)

Street Department

- 1 Maintains all street & street signs
- 2 Update Capital improvement plan (as needed)
- 3 Remove trash from roads & ditches (as needed)
- 4 Plow/Sand all roads (keep track to bill St Joseph twnshp & Maine Prairie Twnshp)
- 5 Keep all equipment maintained
- 6 Keep supplies on hand (signs, posts, cutting edge etc.)
- 7 **Develop & maintain vehicle preventative plan**
- 8 Plow Main Street sidewalks

Parks Department

- 1 Empty garbages (if necessary)

Buildings

- 1 Perform maintenance of all city buildings (check heater, toilets, sinks, heaters, desks, bulbs etc)
- 2 Walk thru All City Building once a month to do routine checks
- 3 City Hall & Fire Department plow parking lot & shovel side walks & emergency exits
- 4 Empty garbages (if necessary)

Miscellaneous

- 1 Code & Sign off on bills
- 2 Order/Purchase Supplies (If necessary)
- 3 Answer phone calls & Emails

Additional

Public Works Department – March 2021 Report

Week 1 of March

- Fabian was out most of the week so we keep moving forward the best we can.
- Jason, our winter plow driver/helper, did come in a couple of days to help out.
- A couple of minor repairs were needed on unit #5 (the small plow truck) these were taken care of in house.
- Lights for the ice rink are now off as there is no longer any ice.
- The snow pile in front of city hall has been hauled out.
- Started looking into a conveyor box for the back of our dump trucks. The cost looks to be about \$4,000 for a new one. I have been looking for a used one for about 6 to 8 months and none seem to be available. It would be used to add material along the edges of the asphalt.

Week 2 of March

- The diamond arm mower arrived this week. We will be using it to cut back the brush and small trees that grow in the ditches and roadsides.
- The TYM tractor was picked up from River Power. A new wiring harness was installed (this repair was covered under warranty).
- Some sanding of the roads needed to be done this week.
- Marty and I met with Justin and the architect Jake via a phone call to discuss the possible new Public Works building. The talk mostly centered on the cost.

Week 3 of March

- Ditch brush and small tree trimming with the diamond arm mower got started this week. All is going well. Some of the cutting looks rough but once the leaves and foliage come back in a month or so, the brush/trees will look better.
- We had some snow to plow this week but with the warmer weather our roads clean off much faster.
- The main lift station in town had some problems this week. I had to call Austin Pumping along with Nelson Electric to pull the pumps. The bearings were bad in one pump and the other had a bad impeller. All repairs are done and the pumps are up and running.

Week 4 of March

- Prepared the city hall parking lot area for Polar Plunge scheduled for Saturday, March 27.
- We began filling in pot holes this week. This will be an ongoing item throughout the spring and summer.
- We had a culvert on Agate Beach Road that was frozen shut.
- Some of the brush that was left behind from the brush cutter was chipped up this week. There will be more cleanup to follow as time permits.
- Voigt's lift station needed some repairs this week. A bad float was found (just a FYI: all of our lift stations are a least 15 years old and as with everything that is mechanical, parts start to break down over time).

Along with the above stated items, there are routine monthly and day-to-day tasks that are done including but not limited to the following:

- Rounds: checking all lift stations and pump houses daily.
- Water tests: to be done weekly - fluoride and chlorine.
- Locates: completed when requested.
- Add enzymes: to ends on the pressurized sewer system along with the lift stations.
- Reports: monthly and weekly reporting for miscellaneous departments including the MDH (Minnesota Department of Health), City Administrator, Council, and Staff.
- Emptying trash containers in parks and city buildings.
- Answer/respond to: phone calls, phone messages, emails, mail, and walk-ins if necessary.
- Meetings: council, staff, developers, trails, vendors, locates, safety, etc.
- Code weekly Public Works bills/invoices and submit to Accounts Payable.
- Employee timesheets.
- Equipment repairs and maintenance.
- Monthly inspections including air filters, fire extinguishers, emergency and exit light inspections.

Renegade Truck Equipment, Inc.
415 Jay Ave SE
PO Box 356
Richmond, MN 56368

QUOTE

City of Rockville
229 Broadway Street East
Rockville, MN 56369
(320) 250-2601
Attn: Gene Van Havermaet
March 30, 2021

Renegade Truck Equipment is pleased to submit the following quote.

Reference:

10' Steel Gravel Body

Details/Description:

DIMENSION

10' x 96"

HEADBOARD

64" high
3/16" AR400 steel construction
10 Ga. cab-shield
Straight front
Shovel holder

SIDES

Smooth sides
32" high
3/16" AR450 steel construction
3/16" x 4" top tube
Walk rail
Steps front & rear
Stowaway ladder
Board pocket (front & rear)

Renegade Truck Equipment, Inc.
415 Jay Ave SE
PO Box 356
Richmond, MN 56368

FLOOR

1/4" AR450 steel construction
8" I- Beam long-sills

TAILGATE

38" high
3/16" AR400 steel construction
Straight gate
10 Ga. outside panel
Center hole for patching
Air trip tailgate

HYDRAULICS

(use on customer truck)

LIGHTS

Whelen strobe system in S.S. light box in rear corner post. (Strobe, S.T.T/ Back up light)

PAINT

Sand blast
Prime & paint
Cab match

Install new sander brackets & side hydraulic manifold
Remount customer vibrator
Remove existing body and mount new body on customers chassis
Mud flaps rear of tires

NOTE: Customer is responsible for any cost increase in parts and/or materials after 4/09/21.

TOTAL \$17,715.76

Renegade Truck Equipment, Inc.
415 Jay Ave SE
PO Box 356
Richmond, MN 56368

Terms and Conditions:

- 1. Quote valid for 10 Days
- 2. Price does not include tax, shipping or delivery
- 3. Down payment of 25% required
- 4. Payment will be due prior to delivery of service and goods

Acknowledgement of Acceptance – please sign and return:

Name

Company

Title

Date

Signature

Corey Lemke
P: (320) 597-5600
F: (320) 597-5619
M: (320) 333-2695
corey@renegadetruckequipment.com

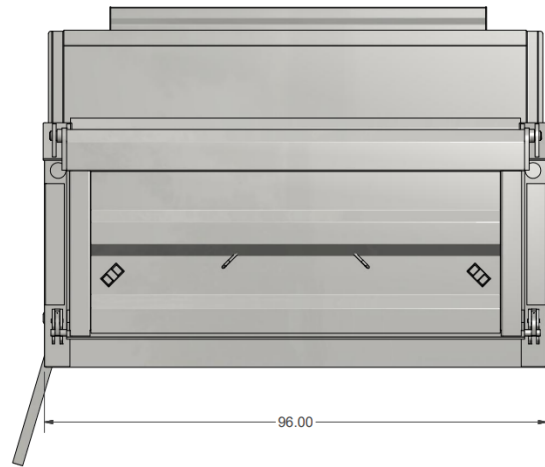
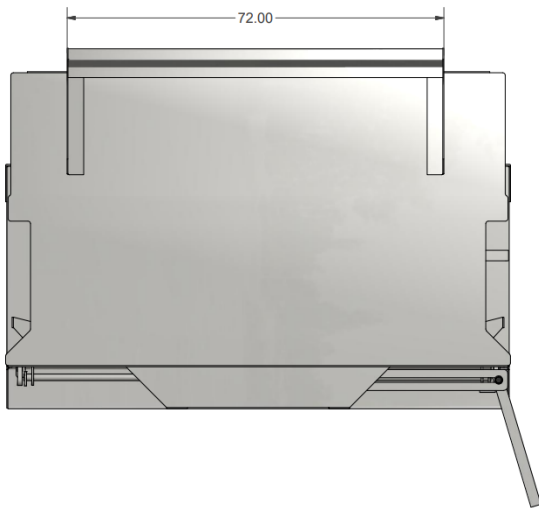
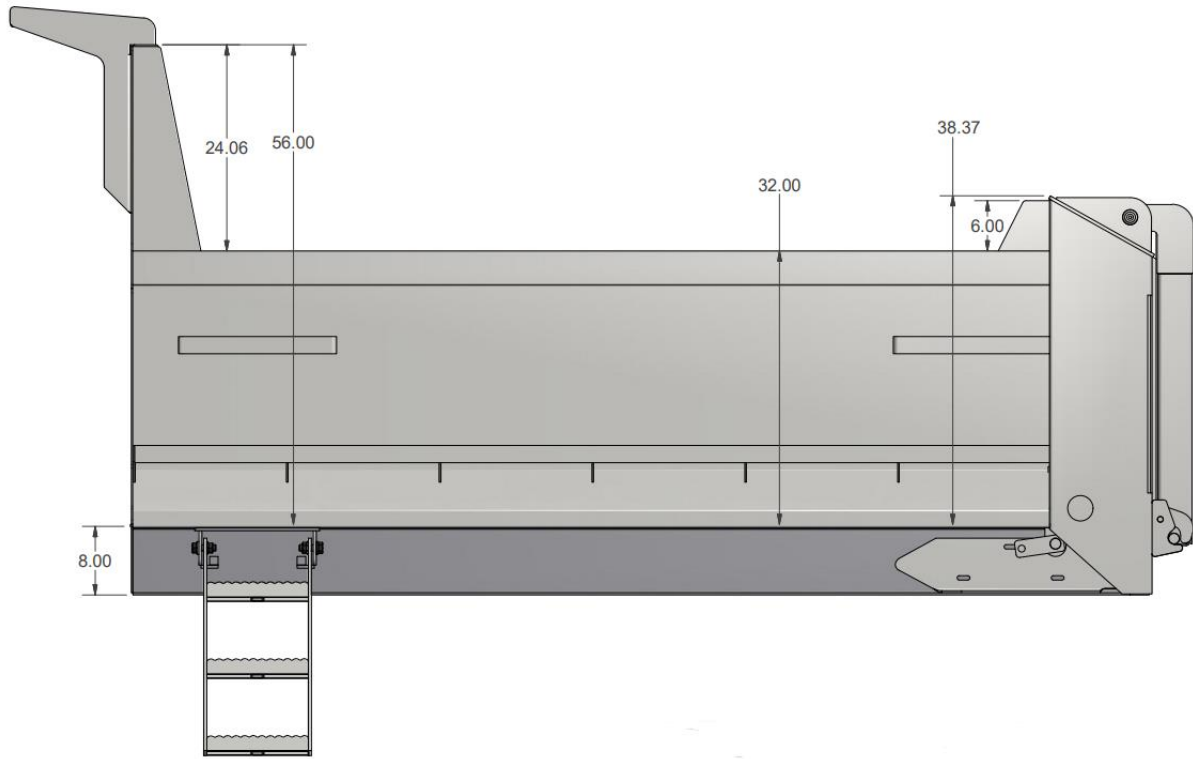

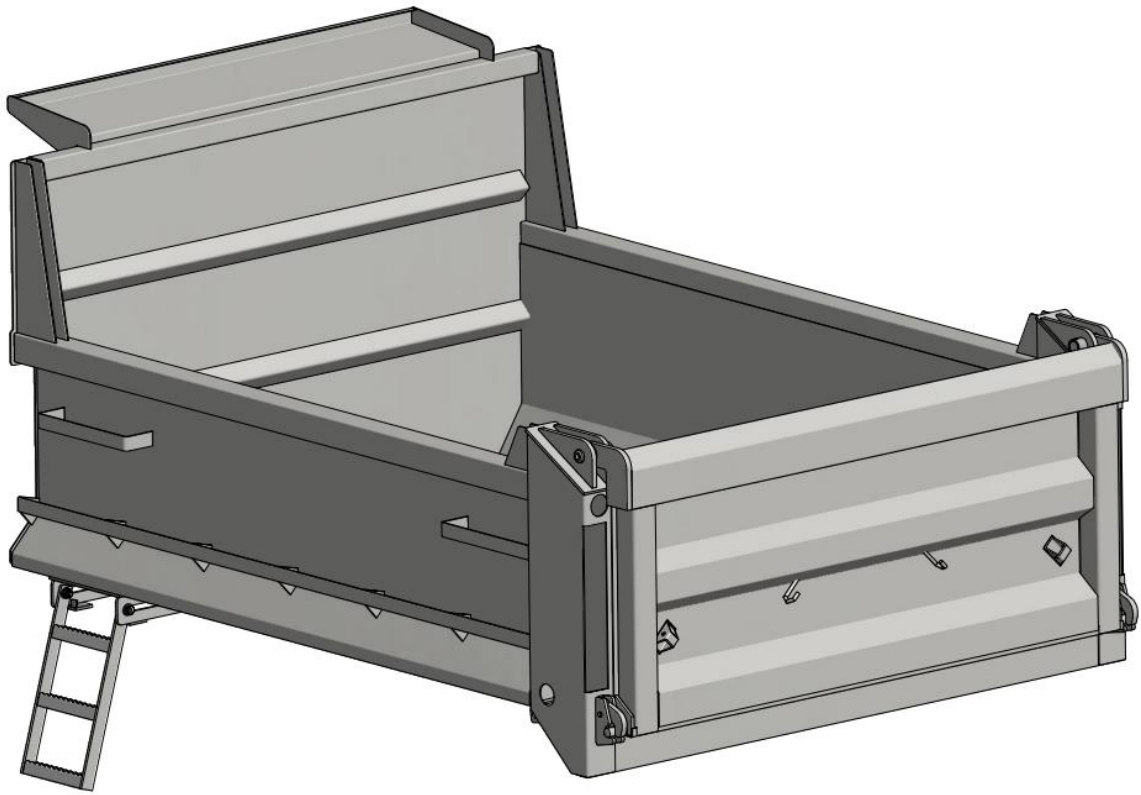

INVOICE

**City of Cold Spring
27 Red River Ave S
Cold Spring, MN 56320**

**Phone: (320) 685-3653
Fax: (320) 685-8551**

City of Rockville
P.O. Box 93
Rockville, MN 56369

Date: March 24, 2021

Charges:

Legal fees from Flaherty & Hood for wastewater agreement

Total Amount Due: \$3,552.50

Thank You!

MAR 26 2021

A Big THANK You for the
use of your parking lot
and Street for hosting
the Polar Plunge.

Much Appreciated: the Polar
Plunge
Committee

Council Action i.e. Appropriations / Transfers / Purchase Requisitions
 April 14, 2021

<u>No.</u>	<u>Description of Appropriations / Transfers / Purchase</u>	<u>Amount</u>	<u>Account No.</u>	<u>Account Desc.</u>	<u>Amend Budget if need necessary</u>	<u>Required / Optional</u>	<u>Meets Fiscal Policy</u>
------------	---	---------------	--------------------	----------------------	---	----------------------------	----------------------------

3 City of Cold Spring Invoice

\$3,552.50 601-49440-

Approved this 14th Day of April, 2021

 Duane Willenbring, Mayor

Attest:

 Martin M. Bode, Administrator-Clerk

<u>No.</u>	<u>Description of Purchase</u>	<u>Account No.</u>	<u>Account Desc.</u>	<u>Required / Optional</u>	<u>Meets Fiscal Policy</u>
------------	--------------------------------	--------------------	----------------------	----------------------------	----------------------------

-